



# Machine Vision Cameras



[www.crevis.co.kr](http://www.crevis.co.kr)



Analog





## Machine Vision Technology

**The FA Vision Solutions of Crevis with Certified reliability and competitive price provide you the Convenience of Interface and prompt technical support based on abundant experiences.**

CREVIS is a leading designer and manufacturer based in Korea in high performance of fieldbus I/O and machine vision cameras. Established in 1999, CREVIS designs, develops, manufactures, and markets distributed I/O and cameras for industrial automation.

Our R&D teams are recognized as world leaders in the field of distributed I/O and digital imaging.

We have quickly gained a reputation among our customers as a company that prides itself on providing technologically superior, high quality, and reliable products with a focus on customers needs and support.

CREVIS customers achieve the benefit of more reasonable price to performance ratios and faster time to market with the company's commitment to high quality, cost effective product solutions.



# Camera Comparison Chart



Interface	Model	Resolution (HxV)	Color	Sensor	Optical Format	fps	Dimension (mm)
GigE	MG-D030B	660 x 494	Mono	CCD	1/3	200	29 x 29 x 40
GigE	MG-D030C	660 x 494	Color	CCD	1/3	200	29 x 29 x 40
GigE	MG-D200B	1644 x 1236	Mono	CCD	1/1.8	50	29 x 29 x 40
GigE	MG-D200C	1644 x 1236	Color	CCD	1/1.8	50	29 x 29 x 40
GigE	MG-D500B	2456 x 2058	Mono	CCD	2/3	15	29 x 29 x 40
GigE	MG-D500C	2456 x 2058	Color	CCD	2/3	15	29 x 29 x 40
GigE	MG-D200B-S	1644 x 1236	Mono	CCD	1/1.8	25	29 x 29 x 40
GigE	MG-D200C-S	1644 x 1236	Color	CCD	1/1.8	25	29 x 29 x 40
GigE	MG-D030B-S	660 x 494	Mono	CCD	1/3	120	29 x 29 x 40
GigE	MG-D030C-S	660 x 494	Color	CCD	1/3	120	29 x 29 x 40
GigE	MG-A040M-280	728 x 544	Mono	CMOS	1/2.9	280	29 x 29 x 40
GigE	MG-A040K-280	728 x 544	Color	CMOS	1/2.9	280	29 x 29 x 40
GigE	MG-A160M-72	1456 x 1088	Mono	CMOS	1/2.9	72	29 x 29 x 40
GigE	MG-A160K-72	1456 x 1088	Color	CMOS	1/2.9	72	29 x 29 x 40
GigE	MG-A320M-35	2064 x 1544	Mono	CMOS	1/1.8	35	29 x 29 x 40
GigE	MG-A320K-35	2064 x 1544	Color	CMOS	1/1.8	35	29 x 29 x 40
GigE	MG-A500M-22	2464 x 2056	Mono	CMOS	2/3	22	29 x 29 x 40
GigE	MG-A500K-22	2464 x 2056	Color	CMOS	2/3	22	29 x 29 x 40
GigE	MG-A121M-9	4112 x 3008	Mono	CMOS	1.1	9	29 x 29 x 40
GigE	MG-A121K-9	4112 x 3008	Color	CMOS	1.1	9	29 x 29 x 40
GigE	MG-A600R-17	3088 x 2072	Mono	CMOS	1/1.8	17	29 x 29 x 40
GigE	MG-A600L-17	3088 x 2072	Color	CMOS	1/1.8	17	29 x 29 x 40
GigE	MG-A121R-9	4024 x 3036	Mono	CMOS	1/1.7	9	29 x 29 x 40
GigE	MG-A121L-9	4024 x 3036	Color	CMOS	1/1.7	9	29 x 29 x 40
GigE	MG-A201R-5	5496 x 3672	Mono	CMOS	1	5	29 x 29 x 40
GigE	MG-A201L-5	5496 x 3672	Color	CMOS	1	5	29 x 29 x 40
GigE	MG-A500P-22	2464 x 2056	Mono	Polarized CMOS	2/3	22	29 x 29 x 40
GigE	MG-A121P-9	4112 x 3008	Mono	Polarized CMOS	1.1	9	29 x 29 x 40
GigE	HG-A130SW	1296 x 1032	Mono	SWIR CMOS	1/2	72	55 x 55 x 74



Interface	Model	Resolution (HxV)	Color	Sensor	Optical Format	fps	Dimension (mm)
Cameralink	MC-D030B	660 x 494	Mono	CCD	1/3	200	29 x 29 x 29
Cameralink	MC-D030C	660 x 494	Color	CCD	1/3	200	29 x 29 x 29
Cameralink	MC-D030B-S	660 x 494	Mono	CCD	1/3	130	29 x 29 x 29
Cameralink	MC-D030C-S	660 x 494	Color	CCD	1/3	130	29 x 29 x 29
Cameralink	MC-D200B	1644 x 1236	Mono	CCD	1/1.8	50	29 x 29 x 29
Cameralink	MC-D200C	1644 x 1236	Color	CCD	1/1.8	50	29 x 29 x 29
Cameralink	MC-D200B-S	1644 x 1236	Mono	CCD	1/1.8	25	29 x 29 x 29
Cameralink	MC-D200C-S	1644 x 1236	Color	CCD	1/1.8	25	29 x 29 x 29
Cameralink	MC-D500B	2456 x 2058	Mono	CCD	2/3	15	29 x 29 x 29
Cameralink	MC-D500C	2456 x 2058	Color	CCD	2/3	15	29 x 29 x 29
Cameralink	MC-A160M-154	1440 x 1080	Mono	CMOS	1/2.9	154	29 x 29 x 29
Cameralink	MC-A160K-154	1440 x 1080	Color	CMOS	1/2.9	154	29 x 29 x 29
Cameralink	MC-A320M-55	2048 x 1536	Mono	CMOS	1/1.8	55	29 x 29 x 29
Cameralink	MC-A320K-55	2048 x 1536	Color	CMOS	1/1.8	55	29 x 29 x 29
Cameralink	MC-A500M-35	2448 x 2048	Mono	CMOS	2/3	35	29 x 29 x 29
Cameralink	MC-A500K-35	2448 x 2048	Color	CMOS	2/3	35	29 x 29 x 29
Cameralink	MC-A121M-20	4096 x 3000	Mono	CMOS	1.1	20	29 x 29 x 29
Cameralink	MC-A121K-20	4096 x 3000	Color	CMOS	1.1	20	29 x 29 x 29
Cameralink	MC-A121R-20	4016 x 3036	Mono	CMOS	1/1.7	20	29 x 29 x 29
Cameralink	MC-A121L-20	4016 x 3036	Color	CMOS	1/1.7	20	29 x 29 x 29

# Camera Comparison Chart



Page.25 ~

Interface	Model	Resolution (HxV)	Color	Sensor	Optical Format	fps	Dimension (mm)
Cameralink	MC-A500M-163	2464 x 2056	Mono	CMOS	2/3	163	29 x 29 x 29
Cameralink	MC-A500K-163	2464 x 2056	Color	CMOS	2/3	163	29 x 29 x 29
Cameralink	MC-A121M-67	4096 x 3000	Mono	CMOS	1.1	67	29 x 29 x 29
Cameralink	MC-A121K-67	4096 x 3000	Color	CMOS	1.1	67	29 x 29 x 29
Cameralink	MC-A500P-163	2464 x 2056	Mono	Polarized CMOS	2/3	163	29 x 29 x 29
Cameralink	MC-A121P-67	4096 x 3000	Mono	Polarized CMOS	1.1	67	29 x 29 x 29
Cameralink	HV-M250C	2048 x 1088	Mono	CMOS	2/3	340	50 x 50 x 34
Cameralink	HV-K250C	2048 x 1088	Color	CMOS	2/3	340	50 x 50 x 34
Cameralink	HV-M400C	2048 x 2048	Mono	CMOS	1	180	50 x 50 x 34
Cameralink	HV-K400C	2048 x 2048	Color	CMOS	1	180	50 x 50 x 34
Cameralink	HC-F251M-31	5120 x 5120	Mono	CMOS	1.1	31	50 x 50 x 34
Cameralink	HC-F251K-31	5120 x 5120	Color	CMOS	1.1	31	50 x 50 x 34
Cameralink	TC-A160K-102	1456 x 1088	Color	CMOS	1/2.9	51	44 x 44 x 74
Cameralink	HC-A130SW	1296 x 1032	Mono	SWIR CMOS	½	134	50 x 50 x 34



Page.43 ~

Interface	Model	Resolution	Color	Sensor	Optical Format	fps	Dimension (mm)
CXP-6	MX-A040M-523	720 x 540	Mono	CMOS	1/2.9	523	29 x 29 x 29
CXP-6	MX-A040K-523	720 x 540	Color	CMOS	1/2.9	523	29 x 29 x 29
CXP-6	MX-A160M-276	1440 x 1080	Mono	CMOS	1/2.9	276	29 x 29 x 29
CXP-6	MX-A160K-276	1440 x 1080	Color	CMOS	1/2.9	276	29 x 29 x 29
CXP-6	MX-A320M-184	2064 x 1544	Mono	CMOS	1/1.8	184	29 x 29 x 29
CXP-6	MX-A320K-184	2064 x 1544	Color	CMOS	1/1.8	184	29 x 29 x 29
CXP-6	MX-A500M-116	2464 x 2056	Mono	CMOS	2/3	116	29 x 29 x 29
CXP-6	MX-A500K-116	2464 x 2056	Color	CMOS	2/3	116	29 x 29 x 29
CXP-6	MX-A890M-66	4096 x 2176	Mono	CMOS	1	66	29 x 29 x 29
CXP-6	MX-A890K-66	4096 x 2176	Color	CMOS	1	66	29 x 29 x 29
CXP-6	MX-A121M-23	4096 x 3000	Mono	CMOS	1.1	23	29 x 29 x 29
CXP-6	MX-A121K-23	4096 x 3000	Color	CMOS	1.1	23	29 x 29 x 29
CXP-6	MX-A121M-48	4096 x 3000	Mono	CMOS	1.1	48	29 x 29 x 29
CXP-6	MX-A121K-48	4096 x 3000	Color	CMOS	1.1	48	29 x 29 x 29
CXP-6	MX-A121R-43	4016 x 3036	Mono	CMOS	1/1.7	43	29 x 29 x 29
CXP-6	MX-A121L-43	4016 x 3036	Color	CMOS	1/1.7	43	29 x 29 x 29
CXP-6	MX-A201R-26	5488 x 3672	Mono	CMOS	1	26	29 x 29 x 29
CXP-6	MX-A201L-26	5488 x 3672	Color	CMOS	1	26	29 x 29 x 29
CXP-6	HX-C471M	7920 x 6004	Mono	CMOS	35mm	30	80 x 80 x 56
CXP-6	HX-C471K	7920 x 6004	Color	CMOS	35mm	30	80 x 80 x 56
CXP-12	HX-F251M-150	5120 x 5120	Mono	CMOS	1.1	150	80 x 80 x 51
CXP-12	HX-F251K-150	5120 x 5120	Color	CMOS	1.1	150	80 x 80 x 51
CXP-12	HX-E361M-43	6144 x 6144	Mono	CMOS	4/3	43	80 x 80 x 44
CXP-12	HX-E361K-43	6144 x 6144	Color	CMOS	4/3	43	80 x 80 x 44
CXP-12	HX-E671M-65	8192 x 8192	Mono	CMOS	APS-C	65	80 x 80 x 44
CXP-12	HX-E671K-65	8192 x 8192	Color	CMOS	APS-C	65	80 x 80 x 44



Page.59 ~

Interface	Model	Resolution	Color	Sensor	Optical Format	fps	Dimension (mm)
USB3.0	MU-A040M-523	728 x 544	Mono	CMOS	1/2.9	523	29 x 29 x 29
USB3.0	MU-A040K-523	728 x 544	Color	CMOS	1/2.9	523	29 x 29 x 29
USB3.0	MU-A160M-226	1456 x 1088	Mono	CMOS	1/2.9	226	29 x 29 x 29
USB3.0	MU-A160K-226	1456 x 1088	Color	CMOS	1/2.9	226	29 x 29 x 29
USB3.0	MU-A320M-118	2064 x 1544	Mono	CMOS	1/1.8	118	29 x 29 x 29
USB3.0	MU-A320K-118	2064 x 1544	Color	CMOS	1/1.8	118	29 x 29 x 29

# Camera Comparison Chart



Page.59 ~

Interface	Model	Resolution	Color	Sensor	Optical Format	fps	Dimension (mm)
USB3.0	MU-A320M-55	2064 x 1544	Mono	CMOS	1/1.8	55	29 x 29 x 29
USB3.0	MU-A320K-55	2064 x 1544	Color	CMOS	1/1.8	55	29 x 29 x 29
USB3.0	MU-A500M-35	2464 x 2056	Mono	CMOS	2/3	35	29 x 29 x 29
USB3.0	MU-A500K-35	2464 x 2056	Color	CMOS	2/3	35	29 x 29 x 29
USB3.0	MU-A500M-75	2464 x 2056	Mono	CMOS	2/3	70	29 x 29 x 29
USB3.0	MU-A500K-75	2464 x 2056	Color	CMOS	2/3	70	29 x 29 x 29
USB3.0	MU-A121M-23	4112 x 3008	Mono	CMOS	1.1	23	29 x 29 x 29
USB3.0	MU-A121K-23	4112 x 3008	Color	CMOS	1.1	23	29 x 29 x 29
USB3.0	MU-A121R-31	4072 x 3046	Mono	CMOS	1/1.7	30	29 x 29 x 29
USB3.0	MU-A121L-31	4072 x 3046	Color	CMOS	1/1.7	30	29 x 29 x 29
USB3.0	MU-A201R-18	5496 x 3672	Mono	CMOS	1	18	29 x 29 x 29
USB3.0	MU-A201L-18	5496 x 3672	Color	CMOS	1	18	29 x 29 x 29

## USB2.0

Page.68 ~

Interface	Model	Resolution	Color	Sensor	Optical Format	fps	Dimension (mm)
USB2.0	MV-BW35U	752 x 480	Mono	CMOS	1/3	60	29 x 29 x 29
USB2.0	MV-CW35U	752 x 480	Color	CMOS	1/3	60	29 x 29 x 29

## Analog

Page.71 ~

Interface	Model	Resolution	Color	Sensor	Optical Format	fps	Dimension (mm)
Analog	MA-D200B	1620 x 1220	Mono	CCD	1/1.8	15	29 x 29 x 29
Analog	MA-D210B	1920 x 1080	Mono	CCD	1/3	15	29 x 29 x 29
Analog	MA-D030B	660 x 494	Mono	CCD	1/3	70	29 x 29 x 29
Analog	MA-D037E	768 x 494	Mono	CCD	1/3	30	29 x 29 x 29
Analog	MV-BX30A	1024 x 772	Mono	CCD	1/3	30	29 x 29 x 29

## LineScan

Page.78 ~

Interface	Model	Resolution	Color	Sensor	Line Rate	Dimension (mm)
Cameralink	LV-M422C	2048 (H) x 2(V)	Mono	CMOS	141KHz	50 x 50 x 40
Cameralink	LV-M824C	4096 (H) x 2(V)	Mono	CMOS	141KHz	50 x 50 x 35.3
Cameralink	LV-M818C	8192 (H) x 1(V)	Mono	CMOS	75KHz	80 x 80 x 34
Cameralink	LV-M8116C	16384 (H) x 1(V)	Mono	CMOS	37.5KHz	80 x 80 x 34
Vision Sensor	SV-B080	8192	Mono	CCD	3.375KHz	85 x 85 x 153.6
Vision Sensor	SV-M020	2048	Mono	CMOS	5KHz	86 x 86 x 137

# SWIR Cameras



## Key Features

- Simultaneous inspection of Visible and SWIR area (400~1700nm)
- Supporting Sensor Cooling Auto Mode (TEC)
- Providing Heat sink for optional

## Pin map

No.	Name	IN/OUT	Description
1	GND	IN	Power GND
2	PWR	IN	10.8V ~ 26.4V Input Range
3	GPI2_ISO-	IN	Trigger2 GND
4	GPI2_ISO+	IN	Opto-Isolated Input, Trigger2 Input
5	GPI1_ISO-	IN	Trigger1 GND
6	GPI1_ISO+	IN	Opto-Isolated Input, Trigger1 Input
7	GPIO1	IN/OUT	General Purpose I/O 1
8	GND	IN	GPIO GND
9	-	-	-
10	GPIO2	IN/OUT	General Purpose I/O 2
11	PWR	IN	10.8V ~ 26.4V Input Range
12	GND	IN	Power GND

## Dimension (Unit : mm)

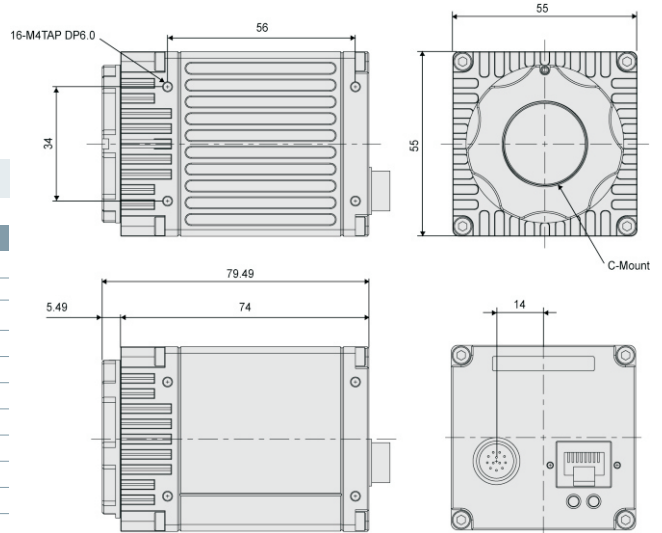

## Applications

### Distinction of same color-materials

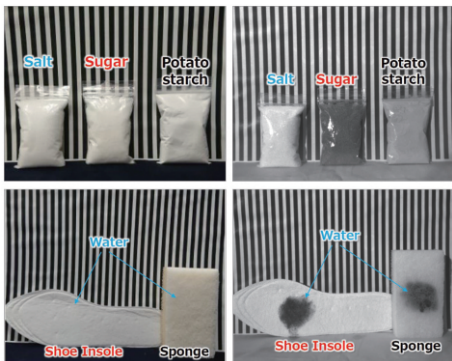

### Examination of invisible parts using permeability

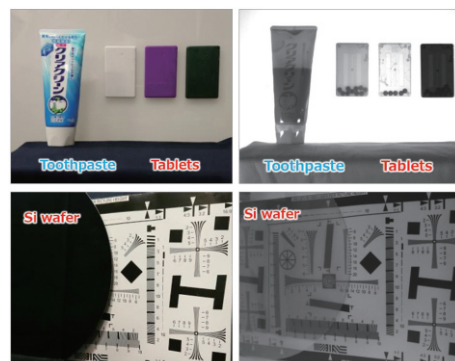



Model	HG-A130SW	HC-A130SW	
Sensor	Sony CMOS Pregius IMX990 Visible + SWIR wideband sensor (0.4um to 1.7um) Built-in thermoelectric cooler (Performance guarantee temperature : +15℃)		
Sensor size	1/2"		
Optical Filter (Optional)	900nm Long Pass		
Pixel size (μm)	5 x 5		
Resolution	1296 x 1032		
CameraLink Pixel Freq.	-	1,2,3Tap : 85MHz	
Frame Rate (Max.)	72fps	134fps	
Scanning method	Full / ROI(Horizontal+Vertical) / Reverse(X,Y,All) / Decimation(X,Y,All) / Binning (X,Y,All)		
Synchronization	Internal(Freerun), External, Software trigger via PC		
Trigger mode	Fixed shutter, Pulse width shutter		
Shutter	Global		
Shutter speed	13.1us ~ 1sec (Exposure Offset 별도)		
Gain	Analog : 0dB ~ 18dB (1x ~ 8x) Digital : 0dB ~ 24dB (1x ~ 16x)		
Black level	Digital : 0 ~ 4095 (12bit)		
Gamma / LUT	Gamma Correction (0~3.999), Adjustable LUT (12bit to 12bit)		
Auto gain / exposure	Off / Once / Continuous		
Interface	Ethernet 1000 Base-T(GigE Vision Standard)	CameraLink	
Pixel Data Format	Mono8/10/12, Mono10/12Packed	Mono8/10/12	
Function control	GainAuto, ExposureAuto, Acquisition Frame Rate(Adjustable), Line Debouncer, Defective Pixel Correction, Noise Reduction Filter, Shading Correction (FFC), Sharpness Enhancement, Contrast / Brightness Control, Sensor Cooling Auto		
Lens mount	C mount		
Power requirements	DC 12V ~ 24V ± 10% or PoE		
Consumption	DC	< 3.8W + 15W (Sensor Cooling Control Max.)	< 3.8W + 15W (Sensor Cooling Control Max.)
	PoE+	< 3.9W (Sensor Cooling Control 별도)	-
Weight	< 330g	< 400g	
Dimension	55 x 55 x 74 mm (without mount)		
Temperature	0℃ ~ 40℃ (Operating) / -20℃ ~ 60℃ (with <20~80% RH) (Storage)	0℃ ~ 30℃ (Operating) / -5℃ ~ 45℃ (with <20~80% RH) (Storage)	
Vibration / Shock	98m/s <sup>2</sup> (10G) / 196m/s <sup>2</sup> (20.0G)		
Standard compliancy	CE (EN61326-1:2006년; Class A)		
Conformity	RoHS, WEEE		
Warranty	3 years		

# Polarization Cameras



## Key Features

- Sony Polarized CMOS Sensor (IMX264/253MZR)
- Interface : GigE, CameraLink
- Resolution : 5MP, 12MP
- Filtering unwanted reflection or glare
- Enhancing contrast
- Stress inspection

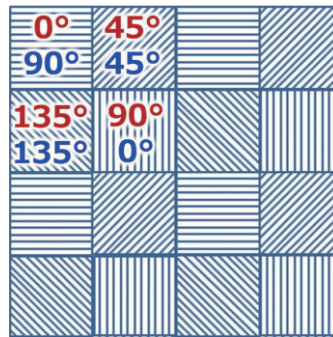

## Specification

Model	MC-A500P-163 MC-A121P-67	MG-A500P-22 MG-A121P-9
Interface	CameraLink	GigE Vision
Pixel size (μm)	3.45 x 3.45	
Resolution	5MP / 12MP	
Sensor size	2/3inch @ 5MP 1.1inch @ 12MP	
Frame Rate (Max.)	Max 163fps @ 5MP Max 67fps @ 12MP	Max 22fps @ 5MP Max 9fps @ 12MP
Features	1. Supporting PoCL 2. Embedded polarization algorithm	1. Supporting PoE 2. Supporting simultaneous image of four different directional polarizing angle 3. Providing SDK and image viewer
Dimension	29 x 29 x 29 mm	29 x 29 x 40 mm
Detailed Specification	<b>37, 38 page</b>	<b>24 page</b>

## Applications

### Improving Contrast

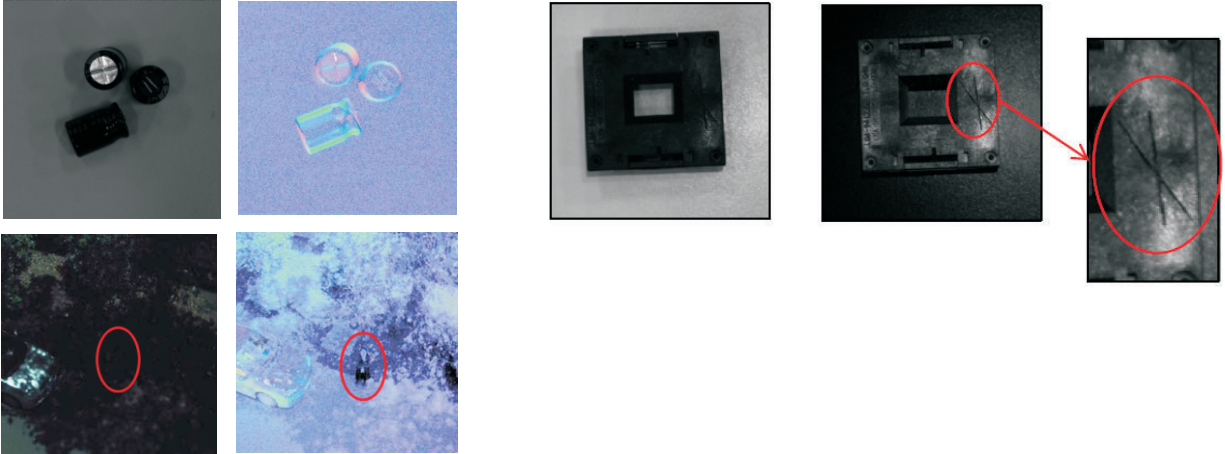

### Reduce Reflection



### Stress Inspection

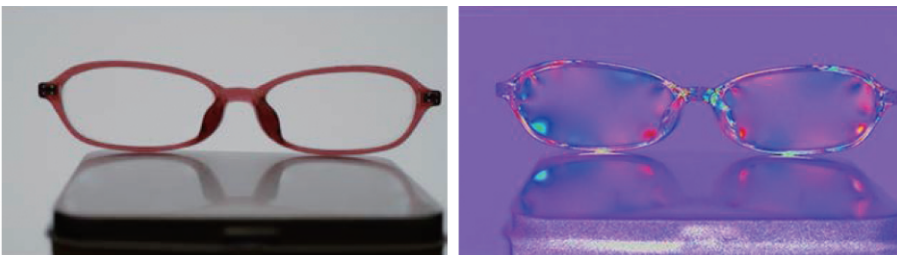

### Scratch inspection of transparent material

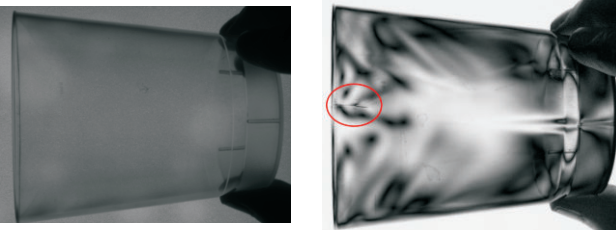

# 3CMOS Cameras



## Key Features

- Sony Pregius IMX273 (x3)
- High frame rate and advanced color fidelity
- Acquisition of each pixel of RGB values
- \* Accurate color values and better resolution as no interpolation process

## Pin map

No.	Name	IN/OUT	Description
1	GND	IN	-
2	PWR	IN	10.8V ~ 26.4V Input Range
3	-	-	-
4	-	-	-
5	Trigger -	IN	Opto-Isolated Trigger Input-
6	Trigger +	IN	Opto-Isolated Trigger Input+(2.5V~24V)
7	GPIO_0	IN/OUT	TTL / Input : 3.3V ~ 24V / Out : 3.3V
8	GND	IN	GPIO GND
9	-	-	-
10	GPIO_1	IN/OUT	TTL / Input : 3.3V ~ 24V / Out : 3.3V
11	PWR	IN	10.8V ~ 26.4V Input Range
12	GND	IN	-

## Dimension (Unit : mm)

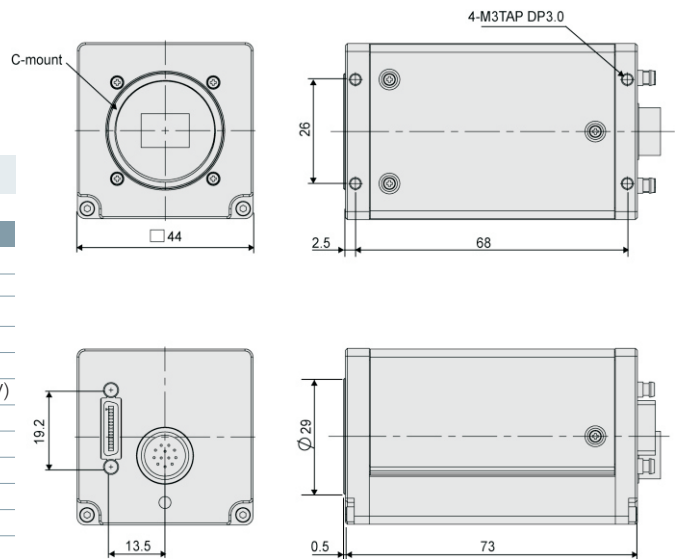

## Image Acquisition Method

### Single Bayer Sensor

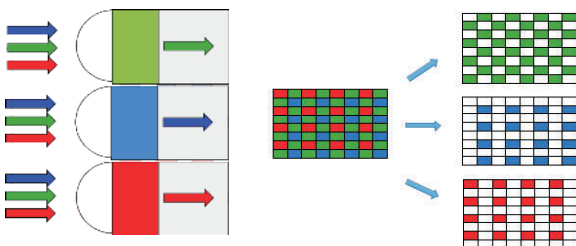

### 3CMOS Sensor

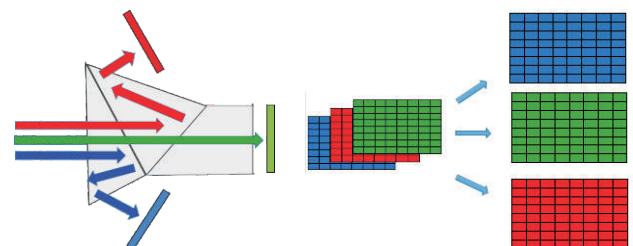

Model	TC-A160K-102	
Sensor	Sony CMOS Preigus IMX273	
Sensor size	1/2.9"	
Pixel size (μm)	3.45 x 3.45	
Resolution	1456 x 1088	
Frame Rate (Max.)	102fps	
Color / Mono	Color	
Scanning method	Full / ROI(Horizontal+Vertical) / Reverse(X,Y,All) / Decimation(X,Y,All) / Binning(Y,All)	
Synchronization	Internal(Freerun) or External (CC1~CC4 / Optocoupler In x2 / GPIO(TTL)x2 / Software)	
Trigger mode	Fixed shutter, Pulse width shutter	
Shutter	Global	
Shutter speed	1us ~ 3sec (Exposure Offset : 별도)	
Gain	Analog : 0dB ~ 36dB (1x ~ 63.1x)	
Black level	Analog : 0 ~ 255 (ADC 8bit) 0 ~ 1023 (ADC 10bit) 0 ~ 4095 (ADC 12bit)	
Gamma / LUT	Gamma Correction (0~3.999), Adjustable LUT (12bit to 12bit)	
Auto white balance	Off / Once / Continuous	
Auto gain / exposure	Off / Once / Continuous	
Interface	Mini CameraLink™, PoCL	
Pixel Data Format	RGB8/RGB10/RGB12	
SNR	35dB	
Function control	GainAuto, ExposureAuto, BalanceWhiteAuto, Acquisition Frame Rate(Adjustable), Line Debouncer, Defective Pixel Correction, Shading Correction(FFC), Color Transformation Control, Noise Reduction	
Lens mount	C mount	
Power requirements	DC 12V ~ 24V ± 10% or PoCL	
Consumption	DC	< 4.5W
	PoCL	
Weight	< 163g	
Dimension	44 x 44 x 73.5 mm (without mount, Connector)	
Temperature	-5℃ ~ 45℃ (Operating) / -20℃ ~ 60℃ (Storage)-(with <20~80% RH)	
Vibration / Shock	98m/s <sup>2</sup> (10G) / 196m/s <sup>2</sup> (20.0G)	
Standard compliancy	CE (EN61326-1;2006년; Class A)	
Conformity	RoHS, WEEE	
Warranty	3 years	

## GigE Vision Cameras



### Key Features

Mini-size CCD / CMOS GigE camera  
 Camera standard  
 - GenICam, GigE Vision  
 Trigger input range : +3.3V~24V(Photo coupler)  
 PoE 지원

### Pin map (H/W Rev 2.0이상)

Pin No.	Name	IN/OUT	Description
1	PWR	IN	10.8V ~ 13.2V Input Range
2	Trigger	IN	Opto-Isolated input, Trigger input
3	GND	IN	Strobe GND
4	Strobe	OUT	Opto-Isolated output, Strobe output
5	GND	IN	Trigger GND
6	GND	IN	Power GND

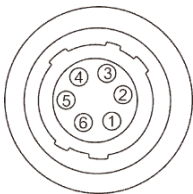

### back Panel

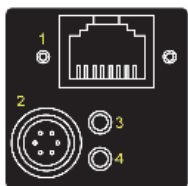

No.	Name	Remark
1	EtherNet Connector	Rj45
2	Power & I/O Connector	6Pin Circular
3,4	LED Indicator	LED

### Dimension (Unit : mm)

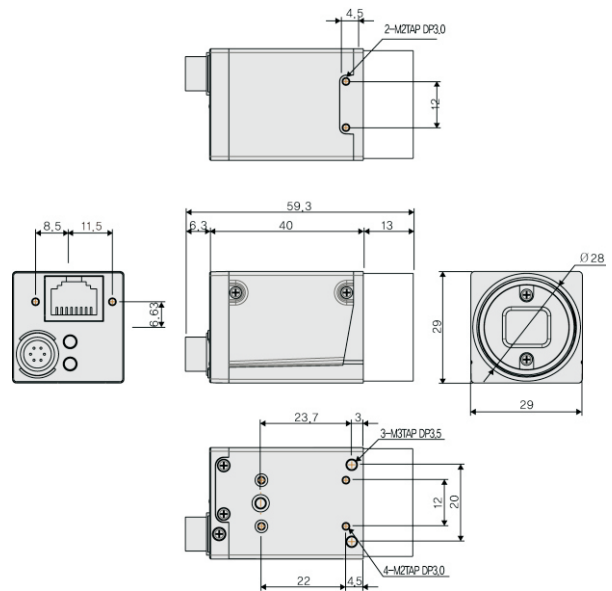

### LED Indicator

LED1	Description	LED2 (3)	Description
OFF	Power off	OFF	Booting or Ready
RED	10/100 Link	RED	IP Assigning
Green	Gigabit Link	Green	Blink(Trigger exist) Grab enabled

### Download (File name)

ex) SDK download:

CREVIS Site ▶ Search window ▶

SDK : [MxCam40\\_SDK.zip](#)

MGE-Installation Guide : [MGE-Installation\\_Guide.pdf](#)

Model (Mono)	MG-D030B (-S)	MG-D200B (-S)	MG-D500B	
(Color)	MG-D030C (-S)	MG-D200C (-S)	MG-D500C	
Sensor size	1/3"	1/1.8"	2/3"	
Image sensor	CCD	CCD	CCD	
Resolution	660 x 494	1644 x 1236	2456 x 2058	
Pixel size (μm)	7.4 x 7.4	4.4 x 4.4	3.45 x 3.45	
Frame Rate (Max.)	200fps (120fps)	50fps (25fps)	15fps	
Image buffer	64MB	64MB	64MB	
Scanning Method	Full / ROI / Decimation (Horizontal+Vertical) / Binning (Only mono models)			
Synchronization	Internal (Freerun), External, Software trigger via PC			
Trigger modes	Timed, Trigger width, Software Trigger mode			
GPIO	Opto-isolated Input (Trigger) x 1, Opto-isolated Output (Strobe) x 1			
Shutter	Global			
Shutter speed	9μs ~ 30sec (11μs ~ 30sec)	14μs ~ 30sec (17μs ~ 30sec)	30μs ~ 30sec	
Pixel data formats	Mono8/10/12, Mono10/12packed Bayer8/10/12, Bayer10/12Packed, YUV422Packed			
Gain	0dB ~ 18dB, (0~12dB, Color 2Tap)			
Gamma / LUT	LUT (12bit to 12bit)			
Exposure control	Programmable via the camera API, External trigger signal			
Interface	EtherNet 1000 Base-T (Gigabit EtherNet)			
Lens mount	C mount			
Power requirements	12VDC ± 10%, PoE (Power over Ethernet 802.3af compliant)			
Weight	< 60g			
Dimension	29mm x 29mm x 40mm			
Temperature	0°C ~ 40°C (Operating) / -10°C ~ 50°C (with <20~80% RH) (Storage)			
Consumption	DC	< 3.3W (2.5W)	< 3.4W (2.7W)	< 3.3W
	POE	< 3.8W (3.1W)	< 4.1W (3.2W)	< 4.1W
Conformity	CE, RoHS, WEEE			
Warranty	3 years			

Model (Mono)	MG-D200B-S	MG-D130B	MG-D030B-S	
(Color)	MG-D200C-S	MG-D130C	MG-D030C-S	
Sensor size	1/1.8"	1/3"	1/3"	
Image sensor	CCD	CCD	CCD	
Resolution	1644 x 1236	1320 x 976	660 x 494	
Pixel size (μm)	4.4 x 4.4	3.75 x 3.75	7.4 x 7.4	
Frame Rate (Max.)	25fps	40fps	120fps	
Image buffer	64MB	64MB	64MB	
Scanning Method	Full / ROI / Decimation (Horizontal+Vertical) / Binning (Only mono models)			
Synchronization	Internal (Freerun), External, Software trigger via PC			
Trigger modes	Timed, Trigger width, Software Trigger mode			
GPIO	Opto-isolated Input (Trigger) x 1, Opto-isolated Output (Strobe) x 1			
Shutter	Global			
Shutter speed	17μs ~ 30sec	18μs ~ 30sec	11μs ~ 30sec	
Pixel data formats	Mono8/10/12, Mono10/12packed Bayer8/10/12, Bayer10/12Packed, YUV422Packed			
Gain	0dB ~ 18dB, (0~12dB, Color 2Tap)			
Gamma / LUT	LUT (12bit to 12bit)			
Exposure control	Programmable via the camera API, External trigger signal			
Interface	EtherNet 1000 Base-T (Gigabit EtherNet)			
Lens mount	C mount			
Power requirements	12VDC ± 10%, PoE (Power over Ethernet 802.3af compliant)			
Weight	< 60g			
Dimension	29mm x 29mm x 40mm			
Temperature	0℃ ~ 40℃ (Operating) / -10℃ ~ 50℃ (with <20~80% RH) (Storage)			
Consumption	DC	< 2.7W	< 2.6W	< 2.5W
	POE	< 3.2W	< 3.2W	< 3.1W
Conformity	CE, RoHS, WEEE			
Warranty	3 years			

Model	MV-MH20G	MV-KH20G
Sensor size	1/2.3"	
Image sensor	CMOS	
Resolution	3856 x 2764	
Pixel size (μm)	1.67 x 1.67	
Frame Rate (Max.)	7fps	
Image buffer	64MB	
Scanning Method	Full / ROI / Decimation (Horizontal+Vertical) / Binning (Not Available : MV-MH20G)	
Synchronization	Internal (Freerun), External, Software trigger via PC	
Trigger modes	Timed, Software	
GPIO	Opto-isolated Input (Trigger) x 1, Opto-isolated Output (Strobe) x 1	
Shutter	Rolling	
Shutter speed	47μs ~ 412ms	
Pixel data formats	Mono8/10/12, mono10/12packed, Bayer8/10/12, Bayer10/12Packed, YUV422Packed	
Gain	0dB ~ 12dB	
Gamma / LUT	LUT (12bit to 12bit)	
Exposure control	Programmable via the camera API, External trigger signal	
Interface	Ethernet 1000 Base-T (Gigabit Ethernet)	
Lens mount	C mount	
Power requirements	12VDC ± 10% , PoE (Power over Ethernet 802.3af compliant)	
Weight	< 60g	
Dimension	29mm x 29mm x 40mm	
Temperature	0°C ~ 40°C (Operating) / -10°C ~ 50°C (with <20~80% RH) (Storage)	
Consumption	DC	< 2.6W
	POE	< 3.4W
Conformity	CE, RoHS, WEEE	
Warranty	3 years	

# GigE Vision Cameras



**Pregius** **STARVIS**



## Key Features

Mini-size / CMOS GigE camera  
 Camera standard  
 - GenICam, GigE Vision  
 Trigger input range : +3.3V~24V(Photo coupler)  
 PoE 지원

## Pin map

Pin No.	Name	IN/OUT	Description
1	PWR	IN	10.8V ~ 13.2V Input Range
2	Trigger	IN	Opto-Isolated input, Trigger input
3	GND	IN	Strobe GND
4	Strobe	OUT	Opto-Isolated output, Strobe output
5	GND	IN	Trigger GND
6	GND	IN	Power GND

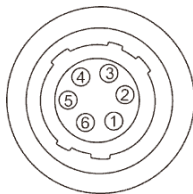

## back Panel

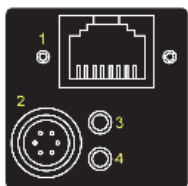

No.	Name	Remark
1	EtherNet Connector	Rj45
2	Power & I/O Connector	6Pin Circular
3,4	LED Indicator	LED

## Dimension (Unit : mm)

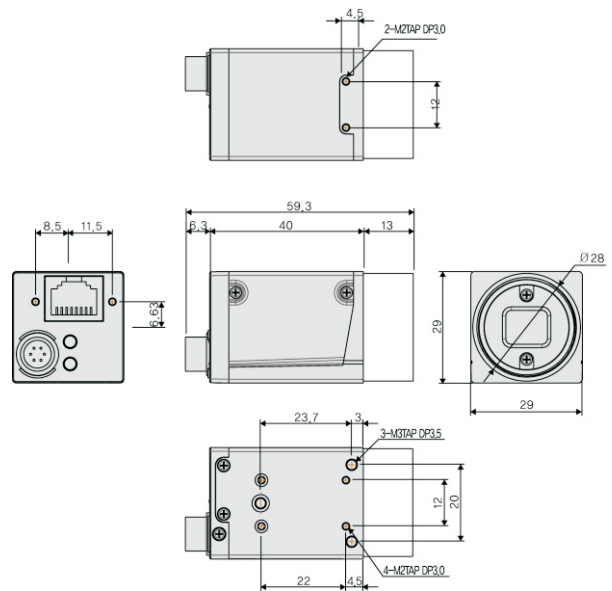

## LED Indicator

LED1	Description	LED2 (3)	Description
OFF	Power off	OFF	Booting or Ready
RED	10/100 Link	RED	IP Assigning
Green	Gigabit Link	Green	Blink(Trigger exist) Grab enabled

## Download (File name)

ex) SDK download:

CREVIS Site ▶ Search window ▶

SDK : [MxCam40\\_SDK.zip](#)

MGE-Installation Guide : [MGE-Installation\\_Guide.pdf](#)

Model	MG-A040M-280	MG-A040K-280
Sensor	Sony CMOS Pregius IMX287	
Sensor size	1/2.9"	
Pixel size (μm)	6.9 x 6.9	
Resolution	728 x 544	
Frame Rate (Max.)	280fps	
Color / Mono	Mono Chrome	Color
Scanning method	Full / ROI / Reverse (X, Y, All)	
Synchronization	Internal (Freerun), External, Software trigger via PC	
Trigger mode	Fixed shutter, Pulse width shutter	
Shutter	Global	
Shutter speed	1us ~ 3sec (Exposure Offset : 별도)	
Gain	Analog : 0dB ~ 32dB (1x ~ 39.8x) Digital : 0dB ~ 24dB (1x ~ 16x)	
Black level	Analog : 0~4095 (12bit) / Digital : 0~4095 (12bit)	
Gamma / LUT	Gamma Correction, Adjustable LUT (12bit to 12bit)	
Auto white balance	Off / Once / Continuous (Only Color Models)	
Auto gain / exposure	Off / Once / Continuous	
Interface	Ethernet 1000 Base-T (GigE Vision Standard)	
Pixel Data Format	Mono8/10/12, Mono10/12 Packed	Mono8/10/12, Mono10/12 Packed, Bayer8/10/12, Bayer10/12 Packed, YUV422 Packed
SNR	37dB	
Function control	GainAuto, ExposureAuto, BalanceWhiteAuto(Only Color Models), Acquisition Frame Rate(Adjustable), Line Debouncer, Color transformation Control, Noise Reduction Filter	
Lens mount	C mount	
Power requirements	12VDC ± 10%, PoE (Power over Ethernet 802.3af compliant)	
Consumption	DC	< 3.1W
	POE	< 3.6W
Weight	< 60g	
Dimension	29 x 29 x 40 mm (without mount)	
Temperature	0°C ~ 40°C (Operating) / -10°C ~ 50°C (Storage)-(with <20~80% RH)	
Vibration / Shock	98m/s <sup>2</sup> (10G) / 196m/s <sup>2</sup> (20.0G)	
Standard compliancy	CE (EN61326-1:2006년; Class A)	
Conformity	RoHS, WEEE, KC, UL	
Warranty	3 years	

Model	MG-A160M-72	MG-A160K-72
Sensor	Sony CMOS Pregius IMX273	
Sensor size	1/2.9"	
Pixel size (μm)	3.45 x 3.45	
Resolution	1456 x 1088	
Frame Rate (Max.)	72fps	
Color / Mono	Mono Chrome	Color
Scanning method	Full / ROI / Reverse(X,Y,All) / Decimation (Horizontal+Vertical) / Binning (Horizontal+Vertical) (Mono Model Only)	
Synchronization	Internal (Freerun), External, Software trigger via PC	
Trigger mode	Fixed shutter, Pulse width shutter	
Shutter	Global	
Shutter speed	1us ~ 3sec (Exposure Offset : 별도)	
Gain	Analog : 0dB ~ 32dB (1x ~ 39.8x) Digital : 0dB ~ 24dB (1x ~ 16x)	
Black level	Analog : 0~4095 (12bit) / Digital : 0~4095 (12bit)	
Gamma / LUT	Gamma Correction, Adjustable LUT (12bit to 12bit)	
Auto white balance	Off / Once / Continuous (Only Color Models)	
Auto gain / exposure	Off / Once / Continuous	
Interface	Ethernet 1000 Base-T (GigE Vision Standard)	
Pixel Data Format	Mono8/10/12, Mono10/12 Packed	Mono8/10/12, Mono10/12 Packed, Bayer8/10/12, Bayer10/12 Packed, YUV422 Packed
SNR	36dB	
Function control	GainAuto, ExposureAuto, BalanceWhiteAuto(Only Color Models), Acquisition Frame Rate(Adjustable), Line Debouncer, Color transformation Control, Noise Reduction Filter	
Lens mount	C mount	
Power requirements	12VDC ± 10%, PoE (Power over Ethernet 802.3af compliant)	
Consumption	DC	< 3.1W
	POE	< 3.6W
Weight	< 60g	
Dimension	29 x 29 x 40 mm (without mount)	
Temperature	0°C ~ 40°C (Operating) / -10°C ~ 50°C (Storage)-(with <20~80% RH)	
Vibration / Shock	98m/s <sup>2</sup> (10G) / 196m/s <sup>2</sup> (20.0G)	
Standard compliancy	CE (EN61326-1:2006년; Class A)	
Conformity	RoHS, WEEE, KC, UL	
Warranty	3 years	

Model	MG-A320M-35	MG-A320K-35
Sensor	Sony CMOS Pregius IMX265	
Sensor size	1/1.8"	
Pixel size ( $\mu\text{m}$ )	3.45 x 3.45	
Resolution	2064 x 1544	
Frame Rate (Max.)	35fps	
Color / Mono	Mono Chrome	Color
Scanning method	Full / ROI / Reverse(X,Y,All) / Decimation (Horizontal+Vertical)	
Synchronization	Internal (Freerun), External, Software trigger via PC	
Trigger mode	Fixed shutter, Pulse width shutter	
Shutter	Global	
Shutter speed	1us ~ 3sec (Exposure Offset : 별도)	
Gain	Analog : 0dB ~ 32dB (1x ~ 39.8x) Digital : 0dB ~ 24dB (1x ~ 16x)	
Black level	Analog : 0~4095 (12bit) / Digital : 0~4095 (12bit)	
Gamma / LUT	Gamma Correction, Adjustable LUT (12bit to 12bit)	
Auto white balance	Off / Once / Continuous (Only Color Models)	
Auto gain / exposure	Off / Once / Continuous	
Interface	Ethernet 1000 Base-T (GigE Vision Standard)	
Pixel Data Format	Mono8/10/12, Mono10/12 Packed	Mono8/10/12, Mono10/12 Packed, Bayer8/10/12, Bayer10/12 Packed, YUV422 Packed
SNR	38dB	
Function control	GainAuto, ExposureAuto, BalanceWhiteAuto(Only Color Models), Acquisition Frame Rate(Adjustable), Line Debouncer, Color transformation Control, Noise Reduction Filter	
Lens mount	C mount	
Power requirements	12VDC $\pm$ 10%, PoE (Power over Ethernet 802.3af compliant)	
Consumption	DC	< 3W
	POE	< 3.5W
Weight	< 60g	
Dimension	29 x 29 x 40 mm (without mount)	
Temperature	0°C ~ 40°C (Operating) / -10°C ~ 50°C (Storage)-(with <20~80% RH)	
Vibration / Shock	98m/s <sup>2</sup> (10G) / 196m/s <sup>2</sup> (20.0G)	
Standard compliancy	CE (EN61326-1:2006년; Class A)	
Conformity	RoHS, WEEE, KC, UL	
Warranty	3 years	

Model	MG-A500M-22	MG-A500K-22
Sensor	Sony CMOS Pregius IMX 264	
Sensor size	2/3"	
Pixel size ( $\mu\text{m}$ )	3.45 x 3.45	
Resolution	2464 x 2056	
Frame Rate (Max.)	22fps	
Color / Mono	Mono Chrome	Color
Scanning method	Full / ROI / Reverse (X,Y,All) / Decimation (Horizontal+Vertical)	
Synchronization	Internal (Freerun), External, Software trigger via PC	
Trigger mode	Fixed shutter, Pulse width shutter	
Shutter	Global	
Shutter speed	1us ~ 3sec (Exposure Offset : 별도)	
Gain	Analog : 0dB ~ 32dB (1x ~ 39.8x) Digital : 0dB ~ 24dB (1x ~ 16x)	
Black level	Analog : 0~4095 (12bit) / Digital : 0~4095 (12bit)	
Gamma / LUT	Gamma Correction, Adjustable LUT (12bit to 12bit)	
Auto white balance	Off / Once / Continuous (Only Color Models)	
Auto gain / exposure	Off / Once / Continuous	
Interface	Ethernet 1000 Base-T (GigE Vision Standard)	
Pixel Data Format	Mono8/10/12, Mono10/12 Packed	Mono8/10/12, Mono10/12 Packed, Bayer8/10/12, Bayer10/12 Packed, YUV422 Packed
SNR	36dB	
Function control	GainAuto, ExposureAuto, BalanceWhiteAuto(Only Color Models), Acquisition Frame Rate(Adjustable), Line Debouncer, Color transformation Control, Noise Reduction Filter	
Lens mount	C mount	
Power requirements	12VDC $\pm$ 10%, PoE (Power over Ethernet 802.3af compliant)	
Consumption	DC	< 3W
	POE	< 3.5W
Weight	< 60g	
Dimension	29 x 29 x 40 mm (without mount)	
Temperature	0°C ~ 40°C (Operating) / -10°C ~ 50°C (Storage)-(with <20~80% RH)	
Vibration / Shock	98m/s <sup>2</sup> (10G) / 196m/s <sup>2</sup> (20.0G)	
Standard compliancy	CE (EN61326-1;2006년; Class A)	
Conformity	RoHS, WEEE, KC, UL	
Warranty	3 years	

Model	MG-A121M-9	MG-A121K-9
Sensor	Sony CMOS Pregius IMX 304	
Sensor size	1.1"	
Pixel size ( $\mu\text{m}$ )	3.45 x 3.45	
Resolution	4112 x 3008	
Frame Rate (Max.)	9fps	
Color / Mono	Mono Chrome	Color
Scanning method	Full / ROI / Reverse(X,Y,All) / Decimation (Horizontal+Vertical)	
Synchronization	Internal (Freerun), External, Software trigger via PC	
Trigger mode	Fixed shutter, Pulse width shutter	
Shutter	Global	
Shutter speed	1us ~ 3sec (Exposure Offset : 별도)	
Gain	Analog : 0dB ~ 32dB (1x ~ 39.8x) Digital : 0dB ~ 24dB (1x ~ 16x)	
Black level	Analog : 0~4095 (12bit) / Digital : 0~4095 (12bit)	
Gamma / LUT	Gamma Correction, Adjustable LUT (12bit to 12bit)	
Auto white balance	Off / Once / Continuous (Only Color Models)	
Auto gain / exposure	Off / Once / Continuous	
Interface	Ethernet 1000 Base-T (GigE Vision Standard)	
Pixel Data Format	Mono8/10/12, Mono10/12 Packed	Mono8/10/12, Mono10/12 Packed, Bayer8/10/12, Bayer10/12 Packed, YUV422 Packed
SNR	42dB	36dB
Function control	GainAuto, ExposureAuto, BalanceWhiteAuto(Only Color Models), Acquisition Frame Rate(Adjustable), Line Debouncer, Color transformation Control, Noise Reduction Filter	
Lens mount	C mount	
Power requirements	12VDC $\pm$ 10%, PoE (Power over Ethernet 802.3af compliant)	
Consumption	DC	< 3.2W
	POE	< 3.7W
Weight	< 60g	
Dimension	29 x 29 x 40 mm (without mount)	
Temperature	0°C ~ 40°C (Operating) / -10°C ~ 50°C (Storage)-(with <20~80% RH)	
Vibration / Shock	98m/s <sup>2</sup> (10G) / 196m/s <sup>2</sup> (20.0G)	
Standard compliancy	CE (EN61326-1:2006년; Class A)	
Conformity	RoHS, WEEE, KC, UL	
Warranty	3 years	

Model	MG-A600R-17	MG-A600L-17
Sensor	Sony CMOS Starvis IMX178	
Sensor size	1/1.8"	
Pixel size ( $\mu\text{m}$ )	2.4 x 2.4	
Resolution	3088 x 2072	
Frame Rate (Max.)	17fps	
Color / Mono	Mono Chrome	Color
Scanning method	Full / ROI(Horizontal+Vertical) / Reverse(X,Y,All) / Binning	
Synchronization	Internal(Freerun), External, Software trigger via PC	
Trigger mode	Fixed shutter, Pulse width shutter	
Shutter	Rolling	
Shutter speed	243.5us ~ 3sec	
Gain	Analog : 0dB ~ 27dB(1x ~ 22.5x) Digital : 0dB ~ 24dB(1x ~ 16x)	
Black level	Analog : 0 ~ 255 (8bit) / Digital : 0 ~ 4095 (12bit)	
Gamma / LUT	Gamma Correction(0 ~ 3.999)	
Auto white balance	Off / Once / Continuous	
Auto gain / exposure	Off / Once / Continuous	
Interface	Ethernet 1000 Base-T (GigE Vision Standard)	
Pixel Data Format	Mono8/10/12, Mono10/12 Packed	Mono8/10/12, Mono10/12Packed, Bayer8/10/12, Bayer10/12Packed, YUV422Packed
SNR	40dB	
Function control	GainAuto, ExposureAuto, BalanceWhiteAuto, Acquisition Frame Rate(Adjustable), Gamma Control, Line Debouncer, Color Transformation Control, Noise Reduction Filter, Pattern Noise Removal	
Lens mount	C mount	
Power requirements	12VDC $\pm$ 10%, PoE (Power over Ethernet 802.3af compliant)	
Consumption	DC	< 3W
	POE	< 3.5W
Weight	< 60g	
Dimension	29 x 29 x 40 mm (without mount)	
Temperature	0°C ~ 40°C (Operating) / -10°C ~ 50°C (Storage)-(with <20~80% RH)	
Vibration / Shock	98m/s <sup>2</sup> (10G) / 196m/s <sup>2</sup> (20.0G)	
Standard compliancy	CE (EN61326-1:2006년; Class A)	
Conformity	RoHS, WEEE, UL	
Warranty	3 years	

Model	MG-A121R-9	MG-A121L-9
Sensor	Sony CMOS Starvis IMX226	
Sensor size	1/1.7"	
Pixel size ( $\mu\text{m}$ )	1.85 x 1.85	
Resolution	4024 x 3036	
Frame Rate (Max.)	9fps	
Color / Mono	Mono Chrome	Color
Scanning method	Full / ROI / Reverse (X, Y, All)	
Synchronization	Internal (Freerun), External, Software trigger via PC	
Trigger mode	Fixed shutter, Pulse width shutter	
Shutter mode	Rolling, Global Reset	
Shutter	313.5 $\mu\text{s}$ ~ 3sec	
Gain	Analog : 0dB ~ 27dB (1x ~ 22.5x) Digital : 0dB ~ 24dB (1x ~ 16x)	
Black level	Analog : 0~255 (8bit) / Digital : 0~4095 (12bit)	
Gamma / LUT	Gamma Correction, Adjustable LUT (12bit to 12bit)	
Auto white balance	Off / Once / Continuous (Only Color Models)	
Auto gain / exposure	Off / Once / Continuous	
Interface	Ethernet 1000 Base-T (GigE Vision Standard)	
Pixel Data Format	Mono8/10/12, Mono10/12 Packed	Mono8/10/12, Mono10/12 Packed, Bayer8/10/12, Bayer10/12 Packed, YUV422 Packed
SNR	40dB	
Function control	Gain Auto, Exposure Auto, Acquisition Frame Rate (Adjustable), Color Transformation Control, Balance White Auto (Only Color Models)	
Lens mount	C mount	
Power requirements	12VDC $\pm$ 10%, PoE (Power over Ethernet 802.3af compliant)	
Consumption	DC	< 3W
	POE	< 3.5W
Weight	< 60g	
Dimension	29 x 29 x 40 mm (without mount)	
Temperature	0 $^{\circ}\text{C}$ ~ 40 $^{\circ}\text{C}$ (Operating) / -10 $^{\circ}\text{C}$ ~ 50 $^{\circ}\text{C}$ (Storage)-(with <20~80% RH)	
Vibration / Shock	98m/s <sup>2</sup> (10G) / 196m/s <sup>2</sup> (20.0G)	
Standard compliancy	CE (EN61326-1:2006년; Class A)	
Conformity	RoHS, WEEE, KC	
Warranty	3 years	

Model	MG-A201R-5	MG-A201L-5
Sensor	Sony CMOS Starvis IMX 183	
Sensor size	1"	
Pixel size ( $\mu\text{m}$ )	2.4 x 2.4	
Resolution	5496 x 3672	
Frame Rate (Max.)	5fps	
Scanning system	Progressive	
Color / Mono	Mono Chrome	Color
Scanning method	Full / ROI / Reverse (X, Y, All)	
Synchronization	Internal (Freerun), External, Software trigger via PC	
Trigger mode	Fixed shutter, Pulse width shutter	
Shutter	Rolling, Global Reset	
Shutter speed	430 $\mu\text{s}$ ~ 3 sec	
Gain Abs	Analog : 0dB ~ 27dB (1x ~ 22.5x) Digital : 0dB ~ 24dB (1x ~ 16x)	
Black level	Analog : 0~255 (8bit) / Digital : 0~4095 (14bit)	
Gamma / LUT	Gamma Correction, Adjustable LUT (10bit to 10bit)	
Auto white balance	Off / Once / Continuous (Only Color Models)	
Auto gain / exposure	Off / Once / Continuous	
Interface	Ethernet 1000 Base-T (GigE Vision Standard)	
Pixel Data Format	Mono8/10, Mono10 Packed	Mono8/10, Mono10 Packed, Bayer8/10 Bayer10 Packed, YUV422 Packed
SNR	39dB	
Function control	GainAuto, ExposureAuto, BalanceWhiteAuto Acquisition Frame Rate(Adjustable), Line Debouncer Color Transformation Control, Noise Reduction Filter	
Lens mount	C mount	
Power requirements	12VDC $\pm$ 10%, PoE (Power over Ethernet 802.3af compliant)	
Consumption	DC	< 3.2W
	PoE	< 3.7W
Weight	< 60g	
Dimension	29 x 29 x 40 mm (without mount)	
Temperature	0°C ~ 40°C (Operating) / -10°C ~ 50°C (Storage)-(with <20~80% RH)	
Vibration / Shock	98m/s <sup>2</sup> (10G) / 196m/s <sup>2</sup> (20.0G)	
Standard compliancy	CE (EN61326-1:2006년; Class A)	
Conformity	RoHS, WEEE, KC	
Warranty	3 years	

# Polarsens

Model	MG-A500P-22	MG-A121P-9
Sensor	Sony CMOS Pregius IMX264MZR	Sony CMOS Pregius IMX253MZR
Sensor size	2/3"	1.1"
Pixel size ( $\mu\text{m}$ )	3.45 x 3.45	
Resolution	2464 x 2056	4112 x 3008
Frame Rate (Max.)	22fps	9fps
Color / Mono	Mono Chrome	
Scanning method	Full / ROI / Reverse (x, y, all)	
Synchronization	Internal(Freerun), External, Software trigger via PC	
Trigger mode	Fixed shutter, Pulse width shutter	
Shutter	Global	
Shutter speed	1us ~ 3sec (Exposure Offset : 별도)	
Gain	Analog : 0dB ~ 32dB (1x ~ 39.8x) Digital : 0dB ~ 24dB (1x ~ 16x)	
Black level	Analog : 0 ~ 4095 (12bit) / Digital : 0 ~ 4095 (12bit)	
Gamma / LUT	Gamma Correction, Adjustable LUT (12bit to 12bit)	
Auto gain / exposure	Off / Once / Continuous	
Interface	Ethernet 1000 Base-T (GigE Vision Standard)	
Pixel Data Format	Mono8/10/12, Bayer8/10, RGB8, Mono10/12 packed	
SNR	36dB	39dB
Function control	GainAuto, ExposureAuto, Acquisition Frame Rate(Adjustable), Line Debouncer, Noise Reduction Filter	
Lens mount	C mount	
Power requirements	DC 12V $\pm$ 10% or PoE (Power over Ethernet 802.3af compliant)	
Consumption	DC	< 3.4W
	PoE	< 3.85W
Weight	< 60g	
Dimension	29 x 29 x 40 mm (without mount)	
Temperature	0°C ~ 40°C (Operating) / -10°C ~ 50°C (Storage)-(with <20~80% RH)	
Vibration / Shock	98m/s <sup>2</sup> (10G) / 196m/s <sup>2</sup> (20.0G)	
Standard compliancy	CE (EN61326-1:2006년; Class A)	
Conformity	RoHS, WEEE, KC	
Warranty	3 years	

# Cameralink Cameras



## Key Features

Mini-size CCD CameraLink camera  
 Standard cameralink interface  
 Trigger input range : +2.7V ~ +24V (TTL)  
 PoCL and CL supported

## Pin map

Pin No.	Name	IN/OUT	Description
1	PWR	IN	10.8V~26.4V Input Range
2	GPIO1	IN/OUT	TTL Input / Output
3	GPIO2	IN/OUT	TTL Input / Output
4	IO_GND	IN	IO_GND
5	NC	-	-
6	GND	IN	Power GND

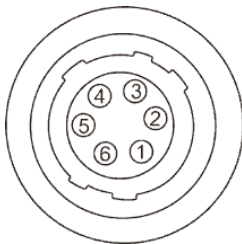

## Dimension (Unit : mm)

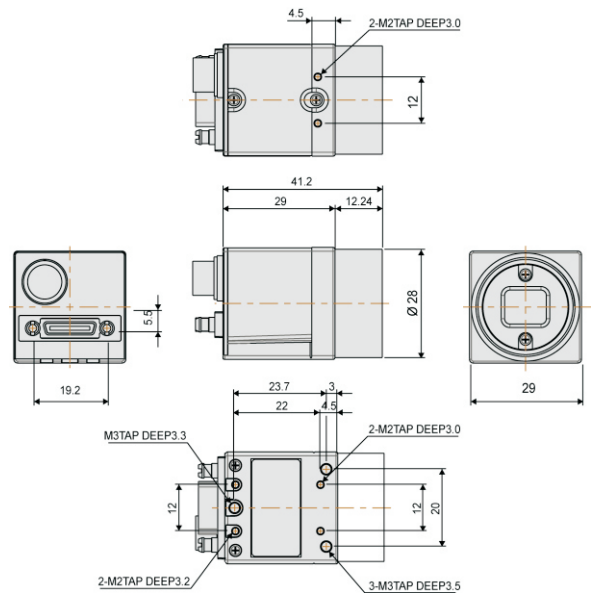

## Download (File name)

ex) SDK download:

CREVIS Site ▶ Search window ▶

CL-Installation Guide : [cameralink\\_manual.zip](#)

Camfile : [cameralink\\_camfile.zip](#)

CamguideCL : [camguideCL.zip](#)

Model (Mono)	MC-D030B(-S)	MC-D130B	MC-D200B(-S)	MC-D500B
(Color)	MC-D030C(-S)	MC-D130C	MC-D200C(-S)	MC-D500C
Sensor size	1/3"	1/3"	1/1.8"	2/3"
Image sensor	CCD	CCD	CCD	CCD
Resolution	660 x 494	1320 x 976	1644 x 1236	2456 x 2058
Pixel size (μm)	7.4 x 7.4	3.75 x 3.75	4.4 x 4.4	3.45 x 3.45
Frame Rate (Max.)	200fps (130fps)	40fps	50fps (25fps)	15fps
Scanning Method	Full / ROI / Binning (Only Mono Models)			
Synchronization	Internal (Freerun) or External (CC 1 or Circular or Software)			
Trigger modes	Timed, Trigger width			
GPIO	TTL GPIO 2ch			
Shutter mode	Global			
Shutter speed	10μs ~ 30sec			
Pixel data formats	Mono : 8, 10 or 12 bit by 14bit ADC Color : 8, 10 or 12 bit Bayer or 8bit RGB by 14bit ADC			
Gain	Mono : 0dB ~ 18dB, Color : 0dB ~ 12dB			
Gamma / LUT	LUT (12bit to 12bit)			
Interface	Mini CameraLink™, PoCL			
Lens mount	C mount			
CameraLink pixel freq.	60MHz (65MHz)	65MHz	41MHz (65MHz)	40MHz
Power requirements	12VDC ± 10%, PoCL			
Weight	< 44g			
Dimension	29mm x 29mm x 29mm			
Temperature	0°C ~ 40°C (Operating) / -10°C ~ 50°C (with < 20~80% RH) (Storage)			
Power consumption	< 2.7W (2.1W)	< 1.9W	< 2.8W (2.2W)	< 2.8W
Vibration / Shock	98m/s <sup>2</sup> (10G) / 196m/s <sup>2</sup> (20G)			
Conformity	CE, RoHS, WEEE			
Warranty	3 years			

# Cameralink Cameras



**Pregius**

**STARVIS**



## Key Features

- Mini-size CMOS CameraLink camera
- Standard cameralink interface
- Trigger input range : +2.7V ~ +24V
- PoCL and CL supported

## Pin map

Pin No.	Name	IN/OUT	Description
1	PWR	IN	10.8V~26.4V Input Range
2	GPIO1	IN/OUT	TTL Input / Output
3	GPIO2	IN/OUT	TTL Input / Output
4	IO_GND	IN	IO_GND
5	NC	-	-
6	GND	IN	Power GND

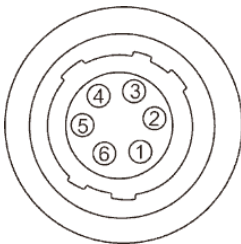

## Dimension (Unit : mm)

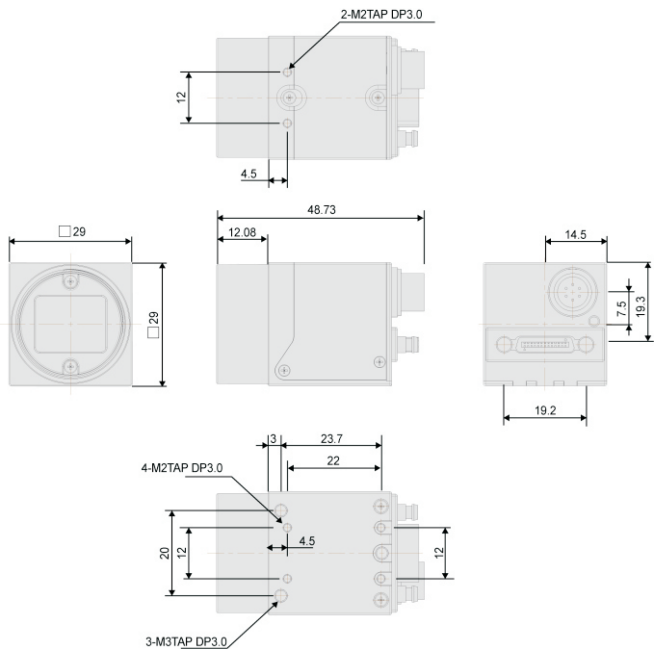

## Download (File name)

ex) SDK download:

CREVIS Site ▶ Search window ▶

CL-Installation Guide : [cameralink\\_manual.zip](#)

Camfile : [cameralink\\_camfile.zip](#)

CamguideCL : [camguideCL.zip](#)

Model	MC-A040M-523	MC-A040K-523
Sensor	Sony CMOS Pregius IMX 287	
Sensor size	1/2.9"	
Pixel size (μm)	6.9 x 6.9	
Resolution	720 x 540	
Frame Rate (Max.)	523fps	
Color / Mono	Mono Chrome	Color
Scanning method	Full / ROI / Reverse (x, y, all)	
Synchronization	Internal(Freerun), External(CC1 or Circular), Software trigger via PC	
Trigger modes	Timed, Trigger width	
Shutter	Global	
Shutter speed	1us ~ 3sec (Exposure Offset : 별도)	
Gain	Analog : 0dB ~ 24dB (1x ~ 15.8x) Digital : 0dB ~ 18dB (1x ~ 8x)	
Black level	Analog : 0~255(ADC 8bit) 0~1023(ADC 10bit) 0~4095(ADC 12bit)/ Digital : 0 ~ 1023 (10bit)	
Gamma / LUT	Gamma Correction, Adjustable LUT (10bit to 10bit)	
Auto white balance	Off / Once / Continuous (Only Color Models)	
Auto gain / exposure	Off / Once / Continuous	
Interface	Mini CameraLink™, PoCL	
Pixel data formats	Mono8/10	Mono8/10, Bayer8/10, RGB8
SNR	37dB	40 dB
Function control	GainAuto, ExposureAuto, BalanceWhiteAuto, Acquisition Frame Rate(Adjustable), Shading Correction(FFC), Color Transformation Control, Noise Reduction Filter	
Lens mount	C mount	
Power requirements	DC 12V ~ 24V ± 10% or PoCL	
Consumption	DC	< 2.1W
	PoCL	
Weight	< 44g	
Dimension	29 x 29 x 29 mm (without mount)	
Temperature	0℃ ~ 45℃ (Operating) / -20℃ ~ 60℃ (Storage)-(with<20~80%RH)	
Vibration / Shock	98m/s <sup>2</sup> (10G) / 196m/s <sup>2</sup> (20.0G)	
Standard compliancy	CE (EN61326-1;2006년; Class A)	
Conformity	RoHS, WEEE, UL	
Warranty	3 years	

Model	MC-A160M-154	MC-A160K-154
Sensor	Sony CMOS Pregius IMX 273	
Sensor size	1/2.9"	
Pixel size (μm)	3.45 x 3.45	
Resolution	1440 x 1080	
Frame Rate (Max.)	154 fps	
Color / Mono	Mono Chrome	Color
Scanning method	Full / ROI / Reverse (x, y, all) / Decimation (Horizontal + Vertical) / Binning (Only Mono models)	
Synchronization	Internal (Freerun), External (CC1 or Circular), Software trigger via PC	
Trigger modes	Timed, Trigger width	
Shutter	Global	
Shutter speed	1us ~ 3sec (Exposure Offset : 별도)	
Gain	Analog : 0dB ~ 24dB (1x ~ 15.8x) Digital : 0dB ~ 18dB (1x ~ 8x)	
Black level	Analog : 0~255(ADC 8bit) 0~1023(ADC 10bit) 0~4095(ADC 12bit)/ Digital : 0 ~ 1023 (10bit)	
Gamma / LUT	Gamma Correction, Adjustable LUT (10bit to 10bit)	
Auto white balance	Off / Once / Continuous (Only Color Models)	
Auto gain / exposure	Off / Once / Continuous	
Interface	Mini CameraLink™, PoCL	
Pixel Data Format	Mono8/10	Mono8/10, Bayer8/10, RGB8
SNR	31dB	35 dB
Function control	GainAuto, ExposureAuto, BalanceWhiteAuto, Acquisition Frame Rate(Adjustable), Shading Correction(FFC), Color Transformation Control, Noise Reduction Filter	
Lens mount	C mount	
Power requirements	DC 12V ~ 24V ± 10% or PoCL	
Consumption	DC	< 2.1W
	PoCL	
Weight	< 44g	
Dimension	29 x 29 x 29 mm (without mount)	
Temperature	0°C ~ 45°C (Operating) / -20°C ~ 60°C (Storage)-(with<20~80%RH)	
Vibration / Shock	98m/s <sup>2</sup> (10G) / 196m/s <sup>2</sup> (20.0G)	
Standard compliancy	CE (EN61326-1:2006년); Class A)	
Conformity	RoHS, WEEE, UL	
Warranty	3 years	

Model	MC-A320M-55	MC-A320K-55
Image sensor	Sony CMOS Pregius IMX 265	
Sensor size	1/1.8"	
Pixel size (μm)	3.45 x 3.45	
Resolution	2048 x 1536 / 3Tap : 2040 x 1536	
Frame Rate (Max.)	55fps	
Color / Mono	Mono Chrome	Color
Scanning method	Full / ROI / Reverse (x, y, all) / Decimation (Horizontal + Vertical)	
Synchronization	Internal(Freerun), External(CC1 or Circular), Software trigger via PC	
Trigger modes	Timed, Trigger width	
Shutter	Global	
Shutter speed	1us ~ 3sec (Exposure Offset : 별도)	
Gain	Analog : 0dB ~ 24dB (1x ~ 15.8x) Digital : 0dB ~ 18dB (1x ~ 8x)	
Black level	Analog : 0 ~ 4095 (12bit) / Digital : 0 ~ 1023 (10bit)	
Gamma / LUT	Gamma Correction, Adjustable LUT (10bit to 10bit)	
Auto white balance	Off / Once / Continuous (Only Color Models)	
Auto gain / exposure	Off / Once / Continuous	
Interface	Mini CameraLink™, PoCL	
Pixel Data Format	Mono8/10	Mono8/10, Bayer8/10, RGB8
SNR	36dB	40dB
Function control	GainAuto, ExposureAuto, BalanceWhiteAuto, Acquisition Frame Rate(Adjustable), Shading Correction(FFC), Color Transformation Control, Noise Reduction Filter	
Lens mount	C mount	
Power requirements	DC 12V ~ 24V ± 10% or PoCL	
Consumption	DC	< 2.1W
	PoCL	
Weight	< 44g	
Dimension	29 x 29 x 29 mm (without mount)	
Temperature	0°C ~ 45°C (Operating) / -20°C ~ 60°C (Storage)-(with<20~80%RH)	
Vibration / Shock	98m/s <sup>2</sup> (10G) / 196m/s <sup>2</sup> (20.0G)	
Standard compliancy	CE (EN61326-1;2006년; Class A)	
Conformity	RoHS, WEEE, UL	
Warranty	3 years	

Model	MC-A500M-35	MC-A500K-35
Sensor	Sony CMOS Pregius IMX 264	
Sensor size	2/3"	
Pixel size (μm)	3.45 x 3.45	
Resolution	2448 x 2048	
Frame Rate (Max.)	35fps	
Color / Mono	Mono Chrome	Color
Scanning method	Full / ROI / Reverse (x, y, all) / Decimation (Horizontal + Vertical)	
Synchronization	Internal(Freerun), External(CC1 or Circular), Software trigger via PC	
Trigger modes	Timed, Trigger width	
Shutter	Global	
Shutter speed	1 us ~ 3sec (Exposure Offset : 별도)	
Gain	Analog : 0dB ~ 24dB (1x ~ 15.8x) Digital : 0dB ~ 18dB (1x ~ 8x)	
Black level	Analog : 0 ~ 4095 (12bit) / Digital : 0 ~ 1023 (10bit)	
Gamma / LUT	Gamma Correction, Adjustable LUT (10bit to 10bit)	
Auto white balance	Off / Once / Continuous (Only Color Models)	
Auto gain / exposure	Off / Once / Continuous	
Interface	Mini CameraLink™, PoCL	
Pixel Data Format	Mono8/10	Mono8/10, Bayer8/10, RGB8
SNR	37dB	41dB
Function control	GainAuto, ExposureAuto, BalanceWhiteAuto, Acquisition Frame Rate(Adjustable), Shading Correction(FFC), Color Transformation Control, Noise Reduction Filter	
Lens mount	C mount	
Power requirements	DC 12V ~ 24V ± 10% or PoCL	
Consumption	DC	< 2.1W
	PoCL	
Weight	< 44g	
Dimension	29 x 29 x 29 mm (without mount)	
Temperature	0°C ~ 45°C (Operating) / -20°C ~ 60°C (Storage)-(with<20~80%RH)	
Vibration / Shock	98m/s <sup>2</sup> (10G) / 196m/s <sup>2</sup> (20.0G)	
Standard compliancy	CE (EN61326-1:2006년); Class A)	
Conformity	RoHS, WEEE, UL	
Warranty	3 years	

Model	MC-A121M-20	MC-A121K-20
Image sensor	Sony CMOS Pregius IMX 304	
Sensor size	1.1"	
Pixel size (μm)	3.45 x 3.45	
Resolution	4096 x 3000 / 3Tap : 4080 x 3000	
Frame Rate (Max.)	20fps	
Color / Mono	Mono Chrome	Color
Scanning method	Full / ROI / Reverse (x, y, all) / Decimation (Horizontal + Vertical)	
Synchronization	Internal(Freerun), External(CC1 or Circular), Software trigger via PC	
Trigger modes	Timed, Trigger width	
Shutter	Global	
Shutter speed	1us ~ 3sec (Exposure Offset : 별도)	
Gain	Analog : 0dB ~ 24dB (1x ~ 15.8x) Digital : 0dB ~ 18dB (1x ~ 8x)	
Black level	Analog : 0 ~ 4095 (12bit) / Digital : 0 ~ 1023 (10bit)	
Gamma / LUT	Gamma Correction, Adjustable LUT (10bit to 10bit)	
Auto white balance	Off / Once / Continuous (Only Color Models)	
Auto gain / exposure	Off / Once / Continuous	
Interface	Mini CameraLink™, PoCL	
Pixel Data Format	Mono8/10	Mono8/10, Bayer8/10, RGB8
SNR	39dB	40dB
Function control	GainAuto, ExposureAuto, BalanceWhiteAuto, Acquisition Frame Rate(Adjustable), Shading Correction(FFC), Color Transformation Control, Noise Reduction Filter	
Lens mount	C mount	
Power requirements	DC 12V ~ 24V ± 10% or PoCL	
Consumption	DC	< 2.3W
	PoCL	
Weight	< 44g	
Dimension	29 x 29 x 29 mm (without mount)	
Temperature	0°C ~ 45°C (Operating) / -20°C ~ 60°C (Storage)-(with<20~80%RH)	
Vibration / Shock	98m/s <sup>2</sup> (10G) / 196m/s <sup>2</sup> (20.0G)	
Standard compliancy	CE (EN61326-1:2006년); Class A)	
Conformity	RoHS, WEEE, UL	
Warranty	3 years	

Model	MC-A121R-20	MC-A121L-20
Image sensor	Sony CMOS Starvis IMX 226	
Sensor size	1/1.7"	
Pixel size (μm)	1.85 x 1.85	
Resolution	4016 x 3036 / 3Tap : 4008 x 3036	
Frame Rate (Max.)	20fps	
Color / Mono	Mono Chrome	Color
Scanning method	Full / ROI / Reverse (x, y, all)	
Synchronization	Internal(Freerun), External(CC1 or Circular), Software trigger via PC	
Trigger modes	Timed, Trigger width	
Shutter	Rolling, Global Reset	
Shutter speed	213.13us~3sec	
Gain	Analog : 0dB ~ 28dB Digital : 0dB ~ 18dB	
Black level	Analog : 0 ~ 255 (10bit) / Digital : 0 ~ 1023 (10bit)	
Gamma / LUT	Gamma Correction, Adjustable LUT (10bit to 10bit)	
Auto white balance	Off / Once / Continuous (Only Color Models)	
Auto gain / exposure	Off / Once / Continuous	
Interface	Mini CameraLink™, PoCL	
Pixel Data Format	Mono8/10	Mono8/10, Bayer8/10, RGB8
SNR	38dB	41dB
Function control	GainAuto, ExposureAuto, BalanceWhiteAuto, Acquisition Frame Rate(Adjustable), Shading Correction(FFC), Color Transformation Control, Noise Reduction Filter	
Lens mount	C mount	
Power requirements	DC 12V ~ 24V ± 10% or PoCL	
Consumption	DC	< 1.9W
	PoCL	
Weight	< 44g	
Dimension	29 x 29 x 29 mm (without mount)	
Temperature	0°C ~ 45°C (Operating) / -20°C ~ 60°C (Storage)-(with<20~80%RH)	
Vibration / Shock	98m/s <sup>2</sup> (10G) / 196m/s <sup>2</sup> (20.0G)	
Standard compliancy	CE (EN61326-1:2006 <sup>準</sup> ; Class A)	
Conformity	RoHS, WEEE	
Warranty	3 years	

# Cameralink Cameras



**Pregius**



## Key Features

Mini-size CMOS CameraLink camera  
 Standard cameralink interface  
 PoCL and CL supported

## Pin map

Pin No.	Name	IN/OUT	Description
1	PWR	IN	10.8V~26.4V Input Range
2	GPIO1	IN/OUT	TTL Input / Output
3	GPIO2	IN/OUT	TTL Input / Output
4	GND	IN	Power GND

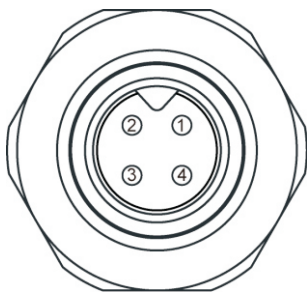

## Dimension (Unit : mm)

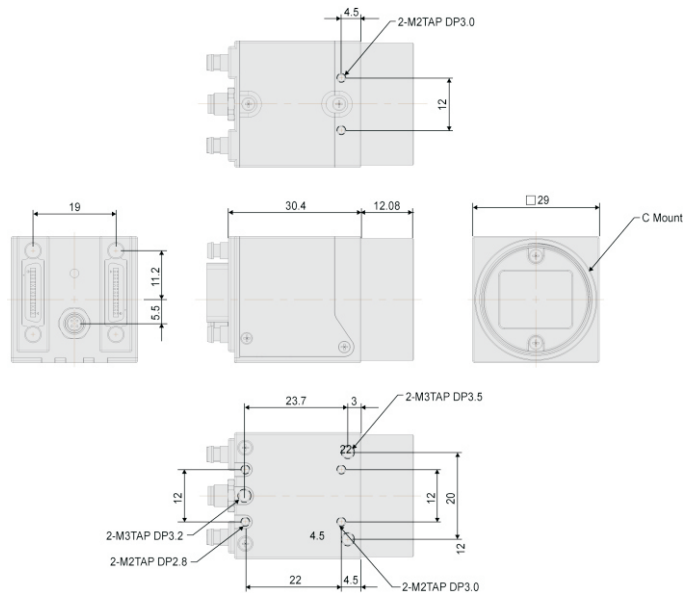

## Download (File name)

ex) SDK download:

CREVIS Site ▶ Search window ▶

CL-Installation Guide : [cameralink\\_manual.zip](#)

Camfile : [cameralink\\_camfile.zip](#)

CamguideCL : [camguideCL.zip](#)

Model	MC-A500M-163	MC-A500K-163
Image sensor	Sony CMOS Pregius IMX 250	
Sensor size	2/3"	
Pixel size (μm)	3.45 x 3.45	
Resolution	2464 x 2056 / 10Tap : 2440 x 2056	
Frame Rate (Max.)	163fps	
Color / Mono	Mono Chrome	Color
Scanning method	Full / ROI / Reverse (x, y, all) / Decimation (Horizontal + Vertical) / Binning (Vertical) Binning (Only Mono models)	
Synchronization	Internal(Freerun), External(CC1 ~ CC4), Software trigger via PC	
Trigger modes	Timed, Trigger width	
Shutter	Global	
Shutter speed	1us ~ 3sec (Exposure Offset : 별도)	
Gain	Analog : 0dB ~ 24dB (1x ~ 15.8x) Digital : 0dB ~ 18dB (1x ~ 8x)	
Black level	Analog : 0 ~ 1023 (10bit) / Digital : 0 ~ 1023 (10bit)	
Gamma / LUT	Gamma Correction, Adjustable LUT (10bit to 10bit)	
Auto white balance	Off / Once / Continuous (Only Color Models)	
Auto gain / exposure	Off / Once / Continuous	
Interface	Mini CameraLink™, PoCL	
Pixel Data Format	Mono8/10	Mono8/10, Bayer8/10, RGB8
SNR	39dB	40dB
Function control	GainAuto, ExposureAuto, BalanceWhiteAuto, Acquisition Frame Rate(Adjustable), Shading Correction(FFC), Color Transformation Control, Noise Reduction Filter	
Lens mount	C mount	
Power requirements	DC 12V ~ 24V ± 10% or PoCL	
Consumption	DC	< 2.2W
	PoCL	
Weight	< 47g	
Dimension	29 x 29 x 29 mm (without mount)	
Temperature	0°C ~ 45°C (Operating) / -20°C ~ 60°C (Storage)- (with<20~80%RH)	
Vibration / Shock	98m/s <sup>2</sup> (10G) / 196m/s <sup>2</sup> (20.0G)	
Standard compliancy	CE (EN61326-1:2006년, Class A)	
Conformity	RoHS, WEEE, UL	
Warranty	3 years	

Model	MC-A121M-67	MC-A121K-67
Image sensor	Sony CMOS Pregius IMX 253	
Sensor size	1.1"	
Pixel size (μm)	3.45 x 3.45	
Resolution	4096 x 3000 / 10Tap : 4080 x 3000	
Frame Rate (Max.)	67fps	
Color / Mono	Mono Chrome	Color
Scanning method	Full / ROI / Reverse(X,Y,All) / Decimation (Horizontal+Vertical) / Binning Vertical, Binning Horizontal Vertical (Only Mono Models)	
Synchronization	Internal(Freerun), External(CC1 ~ CC4), Software trigger via PC	
Trigger modes	Timed, Trigger width	
Shutter	Global	
Shutter speed	1us ~ 3sec (Exposure Offset : 별도)	
Gain	Analog : 0dB ~ 24dB (1x ~ 15.8x) Digital : 0dB ~ 18dB (1x ~ 8x)	
Black level	Analog : 0 ~ 1023 (10bit) / Digital : 0 ~ 1023 (10bit)	
Gamma / LUT	Gamma Correction, Adjustable LUT (10bit to 10bit)	
Auto white balance	Off / Once / Continuous (Only Color Models)	
Auto gain / exposure	Off / Once / Continuous	
Interface	Mini CameraLink™, PoCL	
Pixel Data Format	Mono8/10	Mono8/10, Bayer8/10, RGB8
SNR	38dB	42dB
Function control	GainAuto, ExposureAuto, BalanceWhiteAuto, Acquisition Frame Rate(Adjustable), Shading Correction(FFC), Color Transformation Control, Noise Reduction Filter	
Lens mount	C mount	
Power requirements	DC 12V ~ 24V ± 10% or PoCL	
Consumption	DC	< 2.6W
	PoCL	
Weight	< 47g	
Dimension	29 x 29 x 29 mm (without mount)	
Temperature	0℃ ~ 45℃ (Operating) / -20℃ ~ 60℃ (Storage)-(with<20~80%RH)	
Vibration / Shock	98m/s <sup>2</sup> (10G) / 196m/s <sup>2</sup> (20.0G)	
Standard compliancy	CE (EN61326-1:2006년; Class A)	
Conformity	RoHS, WEEE	
Warranty	3 years	

## Polarsens

Model	MC-A500P-163	
Sensor	Sony CMOS Pregius IMX 250MZR	
Sensor size	2/3"	
Pixel size (μm)	3.45 x 3.45	
Resolution	2464 x 2056 / 10Tap : 2440 x 2056	
Frame Rate (Max.)	163fps	
Color / Mono	Mono Chrome	
Scanning method	Full / ROI / Reverse (x, y, all) / Decimation (Horizontal + Vertical) / Binning (Vertical)	
Synchronization	Internal(Freerun), External(CC1 ~ CC4), Software trigger via PC	
Trigger modes	Timed, Trigger width	
Shutter	Global	
Shutter speed	1us ~ 3sec (Exposure Offset : 별도)	
Gain	Analog : 0dB ~ 24dB (1x ~ 15.8x) Digital : 0dB ~ 18dB (1x ~ 8x)	
Black level	Analog : 0~255(ADC 8bit) 0~1023(ADC 10bit) 0~4095(ADC 12bit) Digital : 0 ~ 1023 (10bit)	
Gamma / LUT	Gamma Correction, Adjustable LUT (10bit to 10bit)	
Auto gain / exposure	Off / Once / Continuous	
Interface	Mini CameraLink™, PoCL	
Pixel data formats	Mono8/10, Bayer8/10, RGB8 Polarization, RGB8 Degree	
Data Output Format	AoP, DoLP, Intensity(S0), 0 degree, 45 degree, 90 degree, 135 degree	
SNR	44dB	
Function control	GainAuto, ExposureAuto, Acquisition Frame Rate(Adjustable), Color Transformation Control, Noise Reduction Filter	
Lens mount	C mount	
Power requirements	DC 12V ~ 24V ± 10% or PoCL	
Consumption	DC	< 3.2W
	PoCL	
Weight	< 47g	
Dimension	29 x 29 x 29 mm (without mount)	
Temperature	0℃ ~ 45℃ (Operating) / -20℃ ~ 60℃ (Storage)-(with<20~80%RH)	
Vibration / Shock	98m/s <sup>2</sup> (10G) / 196m/s <sup>2</sup> (20.0G)	
Standard compliancy	CE (EN61326-1;2006년; Class A)	
Conformity	RoHS, WEEE, UL	
Warranty	3 years	

## Polarsens

Model	MC-A121P-67	
Sensor	Sony CMOS Pregius IMX253MZR	
Sensor size	1.1"	
Pixel size (μm)	3.45 x 3.45	
Resolution	4096 x 3000 / 10Tap : 4080 x 3000	
Frame Rate (Max.)	67fps	
Color / Mono	Mono Chrome	
Scanning method	Full / ROI / Reverse (x, y, all) / Decimation (Horizontal + Vertical) / Binning (Horizontal + Vertical)	
Synchronization	Internal(Freerun), External(CC1 ~ CC4), Software trigger via PC	
Trigger modes	Timed, Trigger width	
Shutter	Global	
Shutter speed	1us ~ 3sec (Exposure Offset : 별도)	
Gain	Analog : 0dB ~ 24dB (1x ~ 15.8x) Digital : 0dB ~ 18dB (1x ~ 8x)	
Black level	Analog : 0~255(ADC 8bit) 0~1023(ADC 10bit) 0~4095(ADC 12bit) Digital : 0 ~ 1023 (10bit)	
Gamma / LUT	Gamma Correction, Adjustable LUT (10bit to 10bit)	
Auto gain / exposure	Off / Once / Continuous	
Interface	Mini CameraLink™, PoCL	
Pixel data formats	Mono8/10, Bayer8/10, RGB8 Polarization, RGB8 Degree	
Data Output Format	AoP, DoIP, Intensity(S0), 0 degree, 45 degree, 90 degree, 135 degree	
SNR	44dB	
Function control	GainAuto, ExposureAuto, Acquisition Frame Rate(Adjustable), Color Transformation Control, Noise Reduction Filter	
Lens mount	C mount	
Power requirements	DC 12V ~ 24V ± 10% or PoCL	
Consumption	DC	< 3.6W
	PoCL	
Weight	< 47g	
Dimension	29 x 29 x 29 mm (without mount)	
Temperature	0℃ ~ 45℃ (Operating) / -20℃ ~ 60℃ (Storage)-(with<20~80%RH)	
Vibration / Shock	98m/s <sup>2</sup> (10G) / 196m/s <sup>2</sup> (20.0G)	
Standard compliancy	CE (EN61326-1;2006년); Class A)	
Conformity	RoHS, WEEE	
Warranty	3 years	

# Cameralink Cameras

2, 4, 25Mega Pixel



## Key Features

- High resolution CCD/ CMOS Cameralink Camera
- Higher frame rates with AOI
- Standard cameralink interface
- Trigger input range : +2.7V~3.3V(TTL), +3.3V~24V(Photo coupler)

## Dimension (Unit : mm)

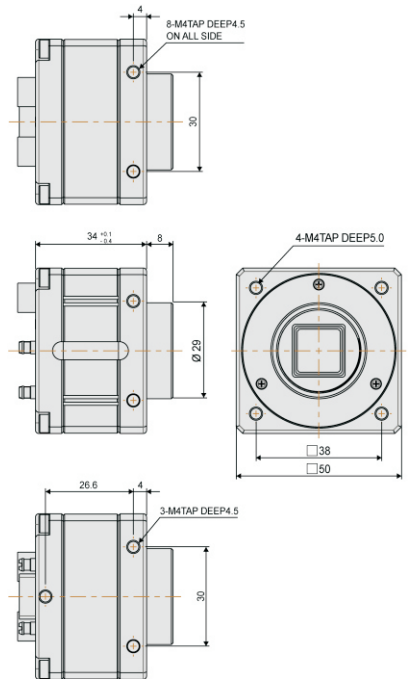

## Pin map

6pin Connector (2M, 4M)

Pin No.	Name	IN/OUT	Description
1	PWR	IN	10.8V~13.2V Input Range
2	PWR	IN	10.8V~13.2V Input Range
3	GPL_TTL	IN	Trigger Input
4	GPO_TTL	OUT	Strobe Output
5	GND	IN	Power GND
6	GND	IN	Power GND

6pin Connector (25M)

Pin No.	Name	IN/OUT	Description
1	PWR	IN	10.8V~26.4V Input Range
2	GPIO1	IN/OUT	Line5
3	GPIO2	IN/OUT	Line6
4	GND	IN	I/O GND
5	NC	-	-
6	GND	IN	Power GND

## Download (File name)

ex) SDK download:

CREVIS Site ▶ Search window ▶

CL-Installation Guide : [cameralink\\_manual.zip](#)

Camfile : [cameralink\\_camfile.zip](#)

CamguideCL : [camguideCL.zip](#)

Model (Mono)	HV-M250C	HV-M400C
(Color)	HV-K250C	HV-K400C
Sensor size	2/3"	1"
Image sensor	CMOS	CMOS
Resolution	2048 x 1088	2048 x 2048
Pixel size (μm)	5.5 x 5.5	5.5 x 5.5
Frame Rate (Max.)	340fps	180fps
Scanning method	Vertical, Horizontal	
Synchronization	Internal (Freerun) or External (CC 1, Circular or Software)	
Trigger modes	Timed, Trigger width	
Shutter	Global	
Shutter speed	10μs~1/Acquisition Frame Rate	
Pixel data formats	Mono 8/10 Bayer 8/10	
Gain	6dB ~ 42dB	
Gamma / LUT	LUT (10bit to 10bit)	
Interface	Mini CameraLink™, PoCL	
Lens mount	C mount	
CameraLink pixel freq.	2,3,4,8Tap : 85MHz 10Tap : 80MHz	
S/N ratio	36dB	
Weight	< 142g	
Dimension	50mm x 50mm x 34mm	
Temperature	0℃ ~ 40℃ (Operating) / -5℃ ~ 45℃ (with <20~80% RH) (Storage)	
Vibration / Shock	IEC 60068-2-6;98m/s <sup>2</sup> (10G) / IEC 60068-2-27;196m/s <sup>2</sup> (20G)	
Power consumption	< 5.0W at 12VDC ± 20%	< 5.5W at 12VDC ± 20%
Conformity	CE, RoHS, WEEE	
Warranty	3 years	

Model	HC-F251M-31
Sensor	GMAX0505 25M
Sensor size	1.1"
Pixel size (μm)	2.5 x 2.5
Resolution	5120 x 5120
CameraLink Pixel Freq.	2, 3, 4, 8, 10Tap : 85MHz
Frame Rate (Max.)	31.7fps
Color / Mono	Mono Chrome
Scanning method	Full / Single ROI / Multi ROI / Reverse(X,Y,All) / Decimation Vertical
Synchronization	Internal(Freerun), External(CC1 ~ CC4 or Circular), Software trigger via PC
Trigger modes	Fixed shutter, Pulse width shutter
Shutter	Global Shutter
Shutter speed	1us ~ 3sec (ExposureOffset : 별도)
Gain	Digital : 0dB ~ 12dB (1x ~ 4x)
Black level	Analog : 0 ~ 2047 / Digital : 0 ~ 1023 (10bit)
Gamma / LUT	Gamma Correction(0 ~ 3.999) / Adjustable LUT (10bit to 10bit)
Interface	CameraLink x2 (PoCL support)
Pixel data formats	Mono8
Data Output Format	AoP, DoIP, Intensity(S0), 0 degree, 45 degree, 90 degree, 135 degree
SNR	37dB
Function control	GainAuto, ExposureAuto, Acquisition Frame Rate(Adjustable), DefectPixelCorrection, NoiseReduction, Shading Correction(FFC, Under 8tap)
Lens mount	C mount
Power requirements	DC(12V ~ 24V ± 10%) or PoCL
Consumption	< 6.0W
Weight	142g
Dimension	50 x 50 x 33.3 mm (Without Mount, Connector)
Temperature	0℃ ~ +40℃ / -5℃ ~ +45℃ (with < 20~80% RH)
Vibration / Shock	98m/s <sup>2</sup> (10G) / 196m/s <sup>2</sup> (20.0G)
Standard compliancy	CE (EN61326-1; 2013; Class A)
Conformity	RoHS, WEEE, CE, UL
Warranty	3 years

Model	HC-F251K-31
Sensor	GMAX0505 25M
Sensor size	1.1"
Pixel size (μm)	2.5 x 2.5
Resolution	5120 x 5120
CameraLink Pixel Freq.	2, 3, 4, 8, 10Tap : 85MHz
Frame Rate (Max.)	31.7fps
Color / Mono	Color
Scanning method	Full / Single ROI / Multi ROI / Reverse(X,Y,All) / Decimation Vertical
Synchronization	Internal(Freerun), External(CC1 ~ CC4 or Circular), Software trigger via PC
Trigger modes	Fixed shutter, Pulse width shutter
Shutter	Global Shutter
Shutter speed	1us ~ 3sec (ExposureOffset : 별도)
Gain	Digital : 0dB ~ 12dB (1x ~ 4x)
Black level	Analog : 0 ~ 2047 / Digital : 0 ~ 1023 (10bit)
Gamma / LUT	Gamma Correction(0 ~ 3.999) / Adjustable LUT (10bit to 10bit)
Interface	CameraLink x2 (PoCL support)
Pixel data formats	Bayer8
Data Output Format	AoP, DoIP, Intensity(S0), 0 degree, 45 degree, 90 degree, 135 degree
SNR	37dB
Function control	GainAuto, ExposureAuto, Acquisition Frame Rate(Adjustable), DefectPixelCorrection, NoiseReduction, Shading Correction(FFC, Under 8tap)
Lens mount	C mount
Power requirements	DC(12V ~ 24V ± 10%) or PoCL
Consumption	< 6.0W
Weight	142g
Dimension	50 x 50 x 33.3 mm (Without Mount, Connector)
Temperature	0℃ ~ +40℃ / -5℃ ~ +45℃ (with < 20~80% RH)
Vibration / Shock	98m/s <sup>2</sup> (10G) / 196m/s <sup>2</sup> (20.0G)
Standard compliancy	CE (EN61326-1; 2013; Class A)
Conformity	RoHS, WEEE, CE, UL
Warranty	3 years

# CoaXpress Cameras



**Pregius**   **STARVIS**

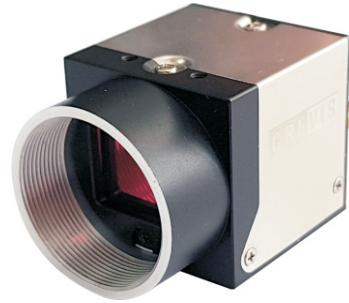

## Key Features

Mini-size CMOS CoaXpress camera  
 Camera standard  
 - GenICam, CoaXpress  
 Trigger input range : +3.3V~24V(Photo coupler)  
 PoCXP 지원

## Pin map

Pin No.	Name	IN/OUT	Description
1	PWR	IN	10.8V~26.4V Input Range
2	Trigger	IN	Opto-Isolated Input, Trigger input
3	GND	OUT	Strobe GND
4	Strobe	OUT	Opto-Isolated output, Strobe output
5	GND	IN	Trigger GND
6	GND	IN	Power GND

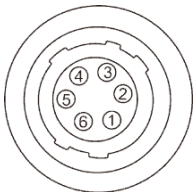

## back Panel

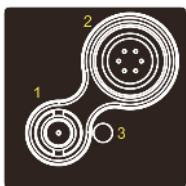

No.	Name	Remark
1	CoaXpress Connector	DIN
2	Power & I/O Connector	6Pin Circular
3	LED Indicator	LED

## Dimension (Unit : mm)

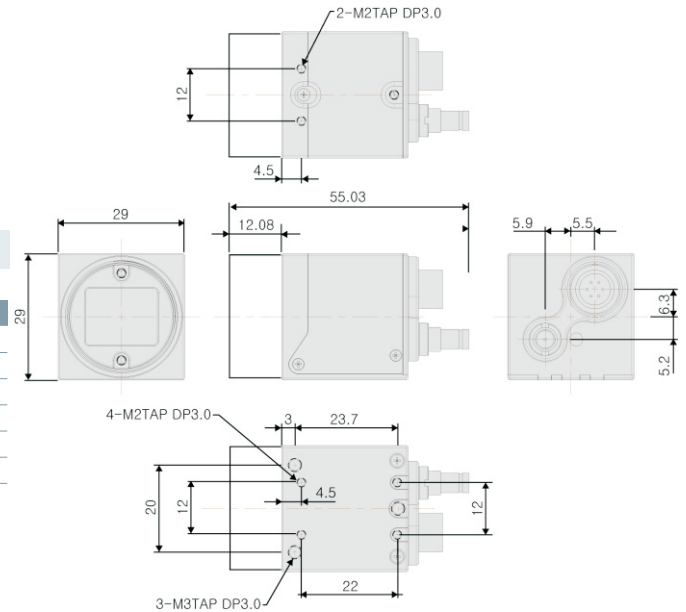

## LED Indicator

State	Indication
No power	Off
System booting	Solid orange
Powered, but nothing connected	Slow pulse red
no data being transferred	Solid green
Waiting for event	Slow pulse orange
Data being transferred	Fast flash green

Model	MX-A040M-523	MX-A040K-523
Sensor	Sony CMOS Pregius IMX287	
Sensor size	1/2.9"	
Pixel size (μm)	6.9 x 6.9	
Resolution	720 x 540	
Frame Rate (Max.)	523fps	
Color / Mono	Mono Chrome	Color
Scanning method	Full / ROI(Horizontal+Vertical) / Reverse(X,Y,All)	
Synchronization	Internal(Freerun), External(CXP or Circular), Software trigger via PC	
Trigger mode	Fixed shutter, Pulse width shutter	
Shutter	Global	
Shutter speed	1us ~ 3sec (Exposure Offset 별도)	
Gain	Analog : 0dB ~ 24dB (1x ~ 15.8x) Digital : 0dB ~ 18dB (1x ~ 8x)	
Black level	Analog : 0 ~ 1023 (10bit) / Digital : 0 ~ 1023 (10bit)	
Gamma / LUT	Gamma Correction, Adjustable LUT (10bit to 10bit)	
Auto white balance	Off / Once / Continuous (Only Color Models)	
Auto gain / exposure	Off / Once / Continuous	
Interface	CoaXpress	
Pixel Data Format	Mono8/10	Mono8/10, Bayer8/10
SNR	33dB	36dB
Function control	GainAuto, ExposureAuto, BalanceWhiteAuto, Acquisition Frame Rate(Adjustable), Shading Correction(FFC), Color Transformation Control, Noise Reduction Filter	
Lens mount	C mount	
Power requirements	DC 12V ~ 24V ± 10% or PoCXP	
Consumption	DC	< 2.5W
	PoCXP	
Weight	< 49g	
Dimension	29 x 29 x 29 mm (without mount)	
Temperature	0℃ ~ 40℃ (Operating) / -5℃ ~ 45℃ (Storage)-(with <20~80% RH)	
Vibration / Shock	98m/s <sup>2</sup> (10G) / 196m/s <sup>2</sup> (20.0G)	
Standard compliancy	CE (EN61326-1:2006년; Class A)	
Conformity	RoHS, WEEE, UL	
Warranty	3 years	

Model	MX-A160M-276	MX-A160K-276
Sensor	Sony CMOS Pregius IMX273	
Sensor size	1/2.9"	
Pixel size ( $\mu\text{m}$ )	3.45 x 3.45	
Resolution	1440 x 1080	
Frame Rate (Max.)	276fps	
Color / Mono	Mono Chrome	Color
Scanning method	Full / ROI / Decimation (Horizontal + Vertical) / Reverse (X, Y, All) / Binning (Only mono models)	
Synchronization	Internal(Freerun), External(CXP or Circular), Software trigger via PC	
Trigger mode	Fixed shutter, Pulse width shutter	
Shutter	Global	
Shutter speed	1us ~ 3sec (Exposure Offset 별도)	
Gain	Analog : 0dB ~ 24dB (1x ~ 15.8x) Digital : 0dB ~ 18dB (1x ~ 8x)	
Black level	Analog : 0 ~ 1023 (10bit) / Digital : 0 ~ 1023 (10bit)	
Gamma / LUT	Gamma Correction, Adjustable LUT (10bit to 10bit)	
Auto white balance	Off / Once / Continuous (Only Color Models)	
Auto gain / exposure	Off / Once / Continuous	
Interface	CoaXpress	
Pixel Data Format	Mono8/10	Mono8/10, Bayer8/10
SNR	34dB	35dB
Function control	GainAuto, ExposureAuto, BalanceWhiteAuto, Acquisition Frame Rate(Adjustable), Shading Correction(FFC), Color Transformation Control, Noise Reduction Filter	
Lens mount	C mount	
Power requirements	DC 12V ~ 24V $\pm$ 10% or PoCXP	
Consumption	DC	< 2.6W
	PoCXP	
Weight	< 49g	
Dimension	29 x 29 x 29 mm (without mount)	
Temperature	0°C ~ 40°C (Operating) / -5°C ~ 45°C (Storage)-(with <20~80% RH)	
Vibration / Shock	98m/s <sup>2</sup> (10G) / 196m/s <sup>2</sup> (20.0G)	
Standard compliancy	CE (EN61326-1;2006년; Class A)	
Conformity	RoHS, WEEE, UL	
Warranty	3 years	

Model	MX-A320M-184	MX-A320K-184
Sensor	Sony CMOS Pregius IMX252	
Sensor size	1/1.8"	
Pixel size (μm)	3.45 x 3.45	
Resolution	2064 x 1544	
Frame Rate (Max.)	184fps	
Color / Mono	Mono Chrome	Color
Scanning method	Full / ROI / Decimation (Horizontal + Vertical) / Reverse (X, Y, All) / Binning (Only mono models) / Binning (Vertical)	
Synchronization	Internal(Freerun), External(CXP or Circular), Software trigger via PC	
Trigger mode	Fixed shutter, Pulse width shutter	
Shutter	Global	
Shutter speed	1us ~ 3sec (Exposure Offset 별도)	
Gain	Analog : 0dB ~ 24dB (1x ~ 15.8x) Digital : 0dB ~ 18dB (1x ~ 8x)	
Black level	Analog : 0 ~ 1023 (10bit) / Digital : 0 ~ 1023 (10bit)	
Gamma / LUT	Gamma Correction, Adjustable LUT (10bit to 10bit)	
Auto white balance	Off / Once / Continuous (Only Color Models)	
Auto gain / exposure	Off / Once / Continuous	
Interface	CoaXpress	
Pixel Data Format	Mono8/10	Mono8/10, Bayer8/10
SNR	38dB	40dB
Function control	GainAuto, ExposureAuto, BalanceWhiteAuto, Acquisition Frame Rate(Adjustable), Shading Correction(FFC), Color Transformation Control, Noise Reduction Filter	
Lens mount	C mount	
Power requirements	DC 12V ~ 24V ± 10% or PoCXP	
Consumption	DC	< 3.1W
	PoCXP	
Weight	< 49g	
Dimension	29 x 29 x 29 mm (without mount)	
Temperature	0℃ ~ 40℃ (Operating) / -5℃ ~ 45℃ (Storage)-(with <20~80% RH)	
Vibration / Shock	98m/s <sup>2</sup> (10G) / 196m/s <sup>2</sup> (20.0G)	
Standard compliancy	CE (EN61326-1;2006년; Class A)	
Conformity	RoHS, WEEE, UL	
Warranty	3 years	

Model	MX-A500M-116	MX-A500K-116
Sensor	Sony CMOS Pregius IMX250	
Sensor size	2/3"	
Pixel size ( $\mu\text{m}$ )	3.45 x 3.45	
Resolution	2464 x 2056	
Frame Rate (Max.)	116fps	
Color / Mono	Mono Chrome	Color
Scanning method	Full / ROI / Decimation (Horizontal + Vertical) / Reverse (X, Y, All) / Binning (Only mono models) / Binning (Vertical)	
Synchronization	Internal(Freerun), External(CXP or Circular), Software trigger via PC	
Trigger mode	Fixed shutter, Pulse width shutter	
Shutter	Global	
Shutter speed	1us ~ 3sec (Exposure Offset 별도)	
Gain	Analog : 0dB ~ 24dB (1x ~ 15.8x) Digital : 0dB ~ 18dB (1x ~ 8x)	
Black level	Analog : 0 ~ 1023 (10bit) / Digital : 0 ~ 1023 (10bit)	
Gamma / LUT	Gamma Correction, Adjustable LUT (10bit to 10bit)	
Auto white balance	Off / Once / Continuous (Only Color Models)	
Auto gain / exposure	Off / Once / Continuous	
Interface	CoaXpress	
Pixel Data Format	Mono8/10	Mono8/10, Bayer8/10
SNR	38dB	40dB
Function control	GainAuto, ExposureAuto, BalanceWhiteAuto, Acquisition Frame Rate(Adjustable), Shading Correction(FFC), Color Transformation Control, Noise Reduction Filter	
Lens mount	C mount	
Power requirements	DC 12V ~ 24V $\pm$ 10% or PoCXP	
Consumption	DC	< 3.1W
	PoCXP	
Weight	< 49g	
Dimension	29 x 29 x 29 mm (without mount)	
Temperature	0°C ~ 40°C (Operating) / -5°C ~ 45°C (Storage)-(with <20~80% RH)	
Vibration / Shock	98m/s <sup>2</sup> (10G) / 196m/s <sup>2</sup> (20.0G)	
Standard compliancy	CE (EN61326-1;2006년; Class A)	
Conformity	RoHS, WEEE, UL	
Warranty	3 years	

Model	MX-A890M-66	MX-A890K-66
Sensor	Sony CMOS Pregius IMX255	
Sensor size	1"	
Pixel size ( $\mu\text{m}$ )	3.45 x 3.45	
Resolution	4096 x 2176	
Frame Rate (Max.)	66fps	
Color / Mono	Mono Chrome	Color
Scanning method	Full / ROI / Decimation (Horizontal + Vertical) / Reverse (X, Y, All) / Binning (Only mono models)	
Synchronization	Internal(Freerun), External(CXP or Circular), Software trigger via PC	
Trigger mode	Fixed shutter, Pulse width shutter	
Shutter	Global	
Shutter speed	1us ~ 3sec (Exposure Offset 별도)	
Gain	Analog : 0dB ~ 24dB (1x ~ 15.8x) Digital : 0dB ~ 18dB (1x ~ 8x)	
Black level	Analog : 0 ~ 1023 (10bit) / Digital : 0 ~ 1023 (10bit)	
Gamma / LUT	Gamma Correction, Adjustable LUT (10bit to 10bit)	
Auto white balance	Off / Once / Continuous (Only Color Models)	
Auto gain / exposure	Off / Once / Continuous	
Interface	CoaXpress	
Pixel Data Format	Mono8/10	Mono8/10, Bayer8/10
SNR	38dB	41dB
Function control	GainAuto, ExposureAuto, BalanceWhiteAuto, Acquisition Frame Rate(Adjustable), Shading Correction(FFC), Color Transformation Control, Noise Reduction Filter	
Lens mount	C mount	
Power requirements	DC 12V ~ 24V $\pm$ 10% or PoCXP	
Consumption	DC	< 3.5W
	PoCXP	
Weight	< 49g	
Dimension	29 x 29 x 29 mm (without mount)	
Temperature	0°C ~ 40°C (Operating) / -5°C ~ 45°C (Storage)-(with <20~80% RH)	
Vibration / Shock	98m/s <sup>2</sup> (10G) / 196m/s <sup>2</sup> (20.0G)	
Standard compliancy	CE (EN61326-1;2006년; Class A)	
Conformity	RoHS, WEEE, UL	
Warranty	3 years	

Model	MX-A121M-23	MX-A121K-23
Sensor	Sony CMOS Pregius IMX304	
Sensor size	1.1"	
Pixel size ( $\mu\text{m}$ )	3.45 x 3.45	
Resolution	4096 x 3000	
Frame Rate (Max.)	23fps	
Color / Mono	Mono Chrome	Color
Scanning method	Full / ROI / Decimation (Horizontal + Vertical) / Reverse (X, Y, All)	
Synchronization	Internal(Freerun), External(CXP or Circular), Software trigger via PC	
Trigger mode	Fixed shutter, Pulse width shutter	
Shutter	Global	
Shutter speed	1us ~ 3sec (Exposure Offset 별도)	
Gain	Analog : 0dB ~ 24dB (1x ~ 15.8x) Digital : 0dB ~ 18dB (1x ~ 8x)	
Black level	Analog : 0 ~ 1023 (10bit) / Digital : 0 ~ 1023 (10bit)	
Gamma / LUT	Gamma Correction, Adjustable LUT (10bit to 10bit)	
Auto white balance	Off / Once / Continuous (Only Color Models)	
Auto gain / exposure	Off / Once / Continuous	
Interface	CoaXpress	
Pixel Data Format	Mono8/10	Mono8/10, Bayer8/10
SNR	38dB	41dB
Function control	GainAuto, ExposureAuto, BalanceWhiteAuto, Acquisition Frame Rate(Adjustable), Shading Correction(FFC), Color Transformation Control, Noise Reduction Filter	
Lens mount	C mount	
Power requirements	DC 12V ~ 24V $\pm$ 10% or PoCXP	
Consumption	DC	< 2.6W
	PoCXP	
Weight	< 49g	
Dimension	29 x 29 x 29 mm (without mount)	
Temperature	0°C ~ 40°C (Operating) / -5°C ~ 45°C (Storage)-(with <20~80% RH)	
Vibration / Shock	98m/s <sup>2</sup> (10G) / 196m/s <sup>2</sup> (20.0G)	
Standard compliancy	CE (EN61326-1;2006년; Class A)	
Conformity	RoHS, WEEE, UL	
Warranty	3 years	

Model	MX-A121M-48	MX-A121K-48
Sensor	Sony CMOS Pregius IMX253	
Sensor size	1.1"	
Pixel size ( $\mu\text{m}$ )	3.45 x 3.45	
Resolution	4096 x 3000	
Frame Rate (Max.)	48fps	
Color / Mono	Mono Chrome	Color
Scanning method	Full / ROI / Decimation (Horizontal + Vertical) / Reverse (X, Y, All) / Binning (Only mono models)	
Synchronization	Internal(Freerun), External(CXP or Circular), Software trigger via PC	
Trigger mode	Fixed shutter, Pulse width shutter	
Shutter	Global	
Shutter speed	1us ~ 3sec (Exposure Offset 별도)	
Gain	Analog : 0dB ~ 24dB (1x ~ 15.8x) Digital : 0dB ~ 18dB (1x ~ 8x)	
Black level	Analog : 0 ~ 1023 (10bit) / Digital : 0 ~ 1023 (10bit)	
Gamma / LUT	Gamma Correction, Adjustable LUT (10bit to 10bit)	
Auto white balance	Off / Once / Continuous (Only Color Models)	
Auto gain / exposure	Off / Once / Continuous	
Interface	CoaXpress	
Pixel Data Format	Mono8/10	Mono8/10, Bayer8/10
SNR	38dB	40dB
Function control	GainAuto, ExposureAuto, BalanceWhiteAuto, Acquisition Frame Rate(Adjustable), Shading Correction(FFC), Color Transformation Control, Noise Reduction Filter	
Lens mount	C mount	
Power requirements	DC 12V ~ 24V $\pm$ 10% or PoCXP	
Consumption	DC	< 3.5W
	PoCXP	
Weight	< 49g	
Dimension	29 x 29 x 29 mm (without mount)	
Temperature	0°C ~ 40°C (Operating) / -5°C ~ 45°C (Storage)-(with <20~80% RH)	
Vibration / Shock	98m/s <sup>2</sup> (10G) / 196m/s <sup>2</sup> (20.0G)	
Standard compliancy	CE (EN61326-1;2006년; Class A)	
Conformity	RoHS, WEEE, UL	
Warranty	3 years	

Model	MX-A121R-43	MX-A121L-43
Sensor	Sony CMOS Starvis IMX226	
Sensor size	1/1.7"	
Pixel size ( $\mu\text{m}$ )	1.85 x 1.85	
Resolution	4016 x 3036	
Frame Rate (Max.)	43fps	
Color / Mono	Mono Chrome	Color
Scanning method	Full / ROI / Reverse (X, Y, All)	
Synchronization	Internal(Freerun), External(CXP or Circular), Software trigger via PC	
Trigger mode	Fixed shutter, Pulse width shutter	
Shutter	Rolling / Global Reset	
Shutter speed	450.00us ~ 3sec	
Gain	Analog : 0dB~27dB (1x ~ 22.5x) Digital : 0dB ~ 18dB (1x ~ 8x)	
Black level	Analog : 0 ~ 1023 (10bit) / Digital : 0 ~ 1023 (10bit)	
Gamma / LUT	Gamma Correction, Adjustable LUT (10bit to 10bit)	
Auto white balance	Off / Once / Continuous (Only Color Models)	
Auto gain / exposure	Off / Once / Continuous	
Interface	CoaXpress	
Pixel Data Format	Mono8/10	Mono8/10, Bayer8/10
SNR	39dB	44dB
Function control	GainAuto, ExposureAuto, BalanceWhiteAuto, Acquisition Frame Rate(Adjustable), Shading Correction(FFC), Color Transformation Control, Noise Reduction Filter	
Lens mount	C mount	
Power requirements	DC 12V ~ 24V $\pm$ 10% or PoCXP	
Consumption	DC	< 2.6W
	PoCXP	
Weight	< 49g	
Dimension	29 x 29 x 29 mm (without mount)	
Temperature	0°C ~ 40°C (Operating) / -5°C ~ 45°C (Storage)-(with <20~80% RH)	
Vibration / Shock	98m/s <sup>2</sup> (10G) / 196m/s <sup>2</sup> (20.0G)	
Standard compliancy	CE (EN61326-1:2006년; Class A)	
Conformity	RoHS, WEEE	
Warranty	3 years	

Model	MX-A201R-26	MX-A201L-26
Sensor	Sony CMOS Starvis IMX183	
Sensor size	1"	
Pixel size ( $\mu\text{m}$ )	2.4 x 2.4	
Resolution	5488 x 3672	
Frame Rate (Max.)	26fps	
Color / Mono	Mono Chrome	Color
Scanning method	Full / ROI / Reverse (X, Y, All)	
Synchronization	Internal(Freerun), External(CXP or Circular), Software trigger via PC	
Trigger mode	Fixed shutter, Pulse width shutter	
Shutter	Rolling / Global Reset	
Shutter speed	806.00us ~ 3sec	
Gain	Analog : 0dB~27dB (1x ~ 22.5x) Digital : 0dB ~ 18dB (1x ~ 8x)	
Black level	Analog : 0 ~ 1023 (10bit) / Digital : 0 ~ 1023 (10bit)	
Gamma / LUT	Gamma Correction, Adjustable LUT (10bit to 10bit)	
Auto white balance	Off / Once / Continuous (Only Color Models)	
Auto gain / exposure	Off / Once / Continuous	
Interface	CoaXpress	
Pixel Data Format	Mono8/10	Mono8/10, Bayer8/10
SNR	38dB	41dB
Function control	GainAuto, ExposureAuto, BalanceWhiteAuto, Acquisition Frame Rate(Adjustable), Shading Correction(FFC), Color Transformation Control, Noise Reduction Filter	
Lens mount	C mount	
Power requirements	DC 12V ~ 24V $\pm$ 10% or PoCXP	
Consumption	DC	< 2.9W
	PoCXP	
Weight	< 49g	
Dimension	29 x 29 x 29 mm (without mount)	
Temperature	0°C ~ 40°C (Operating) / -5°C ~ 45°C (Storage)-(with <20~80% RH)	
Vibration / Shock	98m/s <sup>2</sup> (10G) / 196m/s <sup>2</sup> (20.0G)	
Standard compliancy	CE (EN61326-1:2006년; Class A)	
Conformity	RoHS, WEEE	
Warranty	3 years	

## CoaXPress Cameras



### Key Features

High Resolution CMOS CoaXPress Camera(47MP)  
 Higher frame rates with AOI  
 FFC(Flat Field Correction) Function 지원  
 PoCXP 지원

### Pin map

Power & I/O Connector Pin Assign

Pin No.	Name	IN/OUT	Description
1	PWR	IN	10.8V~25.2V Input Range
2	PWR	IN	10.8V~25.2V Input Range
3	GPIO1	IN/OUT	General purpose I/O (GPIO) line
4	GPIO2	IN/OUT	General purpose I/O (GPIO) line
5	GND	IN	Power GND
6	GND	IN	Power GND

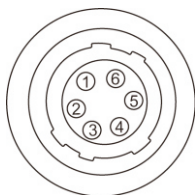

I/O Connector Pin Assign

Pin No.	Name	IN/OUT	Description
1	GPI_ISO+	IN	Opto-Isolated input, Trigger Input
2	GPI_ISO-	IN	Trigger GND
3	GPO_ISO+	OUT	Opto-Isolated Output, Strobe Output
4	GPO_ISO-	OUT	Strobe GND

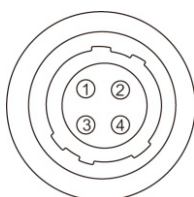

### Dimension (Unit : mm)

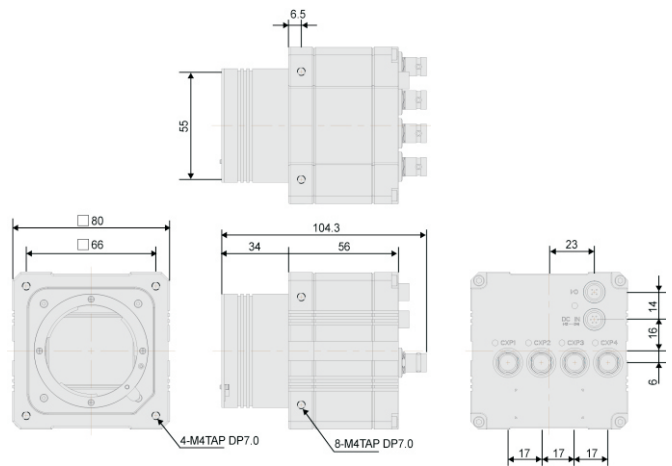

### LED Indicator

State	Indication
No power	Off
System booting	Solid orange
Powered, but nothing connected	Slow pulse red
Connection detection in progress, PoCXP active	Fast flash alternate green / orange
Connection detection in progress, PoCXP not in use	Fast flash orange
Device / Host connected, but no data being transferred	Solid green
Device / Host connected, waiting for event	Slow pulse orange
Performing Function	Solid red

Model	HX-C471M	HX-C471K
Sensor	CMV 50000	
Sensor size	35 mm	
Pixel size ( $\mu\text{m}$ )	4.6 x 4.6	
Resolution	7920 x 6004	
Pixel clock	69MHz	
Frame Rate (Max.)	30fps	
Color / Mono	Mono Crome	Color
Exposure Time	Min. 100us	
Scanning system	Progressive	
Scanning method	Full / ROI / Reverse(X)	
Synchronization	Internal(Freerun), External(CXP or Circular), Software trigger via PC	
Trigger mode	Fixed shutter, Pulse width shutter	
Gain	Digital : 1x ~ 4x	
Black level	Digital : 0 ~ 1023 (10bit)	
Gamma / LUT	Adjustable LUT (12bit to 12bit)	
Auto gain / exposure	Off / Once / Continuous	
Interface	CoaXpress	
Pixel Data Format	Mono Model : Mono8/10/12	
Minimum illumination	1.0 lx, F1.4, Gain MAX, without IR cut filter	
SNR	36dB	
Function control	GainAuto, ExposureAuto, Acquisition Frame Rate(Adjustable)	
Lens mount	F mount	
Power requirements	12~24VDC $\pm$ 10% or PoCXP	
Consumption	< 12.0W at 24Vdc $\pm$ 10%	
Weight	< 579g (With F-Mount)	
Dimension	80 x 80 x 56 mm (Without mount, Connector)	
Temperature	0 $^{\circ}$ C ~ 40 $^{\circ}$ C (Operating) / -10 $^{\circ}$ C ~ 50 $^{\circ}$ C (with < 20~80% RH) (Storage)	
Vibration / Shock	98m/s <sup>2</sup> (10G) / 490m/s <sup>2</sup> (50.0G)	
Standard compliancy	CE (EN61326-1:2006년; Class A)	
Conformity	RoHS, WEEE	
Warranty	3 years	

# CoaXPress 2.0 Cameras



## Key Features

High resolution CMOS CoaXPress2.0 Camera (25/36/67M)  
 Supporting FFC  
 Supporting PoCXP  
 12.5Gbps x 4ch  
 Max Cable Length : 30meter @ CXP12

## Back Panel

Pin No.	Name	Description
1	CoaxPress Connector 1	MicroBNC Type
2	CoaxPress Connector 2	MicroBNC Type
3	CoaxPress Connector 3	MicroBNC Type
4	CoaxPress Connector 4	MicroBNC Type
5	LED Indicator 1	LED
6	LED Indicator 2	LED
7	LED Indicator 3	LED
8	LED Indicator 4	LED
9	I/O Connector	4 Pin Circular Connector

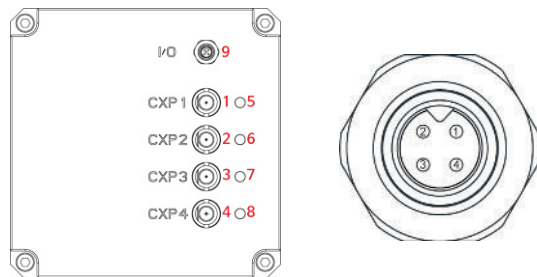

## Dimension (Unit : mm)

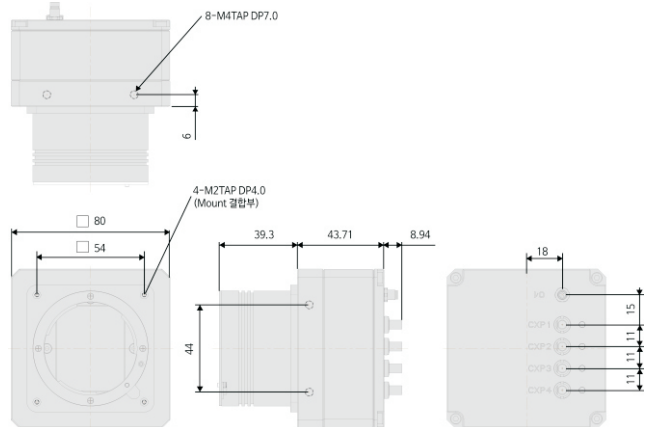

## LED Indicator

State	Indication
No power	Off
System booting	Solid orange
Powered, but nothing connected	Slow pulse red
Connection detection in progress, PoCXP active	Fast flash alternate green / orange
Connection detection in progress, PoCXP not in use	Fast flash orange
Device / Host connected, but no data being transferred	Solid green
Device / Host connected, waiting for event	Slow pulse orange

## 4 pin Circular Connector

Pin No.	Name	IN/OUT	Description
1	GPIO1	IN/OUT	LINE2 (Direct IO, 3.3V)
2	GND	IN	Direct IO GND
3	GPIO2	IN/OUT	LINE3 (Direct IO, 3.3V)
4	GND	IN	Direct IO GND

Model	HX-F251M-150	HX-F251K-150
Sensor	GMAX0505 25M	
Sensor size	1.1"	
Pixel size ( $\mu\text{m}$ )	2.5 x 2.5	
Resolution	5120 x 5120	
Pixel Clock	96MHz	
Frame Rate (Max.)	150fps	
Color / Mono	Mono Chrome	Color
Scanning method	Full / ROI(Horizontal+Vertical) / Reverse(X), Decimation(Y)	
Synchronization	Internal(Freerun), External(CXP or Circular), Software trigger via PC	
Trigger mode	Fixed shutter, Pulse width shutter	
Shutter	Global	
Shutter speed	1us ~ 3sec (Exposure Offset 별도)	
Gain	Digital : 1x ~ 4x	
Black level	Digital : 0 ~ 1023 (10bit)	
Gamma / LUT	Adjustable LUT (10bit to 10bit)	
Auto white balance	Off / Once / Continuous	
Auto gain / exposure	Off / Once / Continuous	
Interface	CoaxPress Standard	
Pixel Data Format	Mono8	Bayer8
SNR	36dB	
Function control	GainAuto, ExposureAuto, BalanceWhiteAuto, Acquisition Frame Rate(Adjustable), Defective Pixel Correction, Shading Correction(FFC), Noise Reduction Filter	
Lens mount	C mount	
Video I/F	CoaXPress / Micro-BNC	
Power requirements	PoCXP (Two PoCXP cables required)	
Consumption	PoCXP	
Weight	< 450g	
Dimension	80 x 80 x 50.56 mm (without connector)	
Temperature	0°C ~ 35°C (Operating) / -20°C ~ 60°C (with < 20~80% RH) (Storage)	
Vibration / Shock	98m/s <sup>2</sup> (10G) / 196m/s <sup>2</sup> (20.0G)	
Standard compliancy	CE (EN61326-1:2013년; Class A)	
Conformity	RoHS, WEEE, UL	
Warranty	3 years	

Model	HX-E361M-43	HX-E361K-43
Sensor	EMERALD 36M	
Sensor size	4/3"	
Pixel size ( $\mu\text{m}$ )	2.5 x 2.5	
Resolution	6144 x 6144	
Pixel Clock	75.4MHz	
Frame Rate (Max.)	43fps	
Color / Mono	Mono Chrome	Color
Scanning method	Full / ROI(Horizontal+Vertical) / Reverse(X,Y,All)	
Synchronization	Internal(Freerun), External(CXP or Circular), Software trigger via PC	
Trigger mode	Fixed shutter, Pulse width shutter	
Shutter	Global	
Shutter speed	1us ~ 3sec (Exposure Offset 별도)	
Gain	Analog : 1x ~ 3.99x Digital : 1x ~ 4x	
Black level	Digital : 0 ~ 1024 (10bit)	
Gamma / LUT	Adjustable LUT (10bit to 10bit)	
Auto white balance	Off / Once / Continuous	
Auto gain / exposure	Off / Once / Continuous	
Interface	CoaxPress Standard	
Pixel Data Format	Mono8/10	Bayer8/10
SNR	37dB	
Function control	GainAuto, ExposureAuto, BalanceWhiteAuto, Acquisition Frame Rate(Adjustable), Defective Pixel Correction, Shading Correction(FFC), Noise Reduction Filter	
Lens mount	F mount	
Video I/F	CoaXPress / Micro-BNC	
Power requirements	PoCXP (Two PoCXP cables required)	
Consumption	PoCXP	
Weight	< 461g	
Dimension	80 x 80 x 44.14 mm (without connector)	
Temperature	0°C ~ 45°C (Operating) / -20°C ~ 60°C (with < 20~80% RH) (Storage)	
Vibration / Shock	98m/s <sup>2</sup> (10G) / 196m/s <sup>2</sup> (20.0G)	
Standard compliancy	CE (EN61326-1;2013년); Class A)	
Conformity	RoHS, WEEE, UL	
Warranty	3 years	

Model	HX-E671M-65	HX-E671K-65
Sensor	EMERALD 67M	
Sensor size	APS-C	
Pixel size (μm)	2.5 x 2.5	
Resolution	8192 x 8192	
Pixel Clock	75.4MHz	
Frame Rate (Max.)	65fps	
Color / Mono	Mono Chrome	Color
Scanning method	Full / ROI(Horizontal+Vertical) / Reverse(X,Y,All)	
Synchronization	Internal(Freerun), External(CXP or Circular), Software trigger via PC	
Trigger mode	Fixed shutter, Pulse width shutter	
Shutter	Global	
Shutter speed	1us ~ 3sec (Exposure Offset 별도)	
Gain	Analog : 1x ~ 3.99x Digital : 1x ~ 4x	
Black level	Digital : 0 ~ 1024 (10bit)	
Gamma / LUT	Adjustable LUT (10bit to 10bit)	
Auto white balance	Off / Once / Continuous	
Auto gain / exposure	Off / Once / Continuous	
Interface	CoaxPress Standard	
Pixel Data Format	Mono8/10	Bayer8/10
SNR	36dB	
Function control	GainAuto, ExposureAuto, BalanceWhiteAuto, Acquisition Frame Rate(Adjustable), Defective Pixel Correction, Shading Correction(FFC), Noise Reduction Filter	
Lens mount	F mount	
Video I/F	CoaXPress / Micro-BNC	
Power requirements	PoCXP (Two PoCXP cables required)	
Consumption	PoCXP	
Weight	< 461g	
Dimension	80 x 80 x 44.14 mm (without connector)	
Temperature	0℃ ~ 45℃ (Operating) / -20℃ ~ 60℃ (with < 20~80% RH) (Storage)	
Vibration / Shock	98m/s <sup>2</sup> (10G) / 196m/s <sup>2</sup> (20.0G)	
Standard compliancy	CE (EN61326-1:2013년); Class A)	
Conformity	RoHS, WEEE, UL	
Warranty	3 years	

## USB3.0 Cameras



### Key Features

Camera Standard  
 - GenICam, USB3Vision  
 Plug & Play  
 Max Cable length : 5meter

### Pin map

6pin Connector

Pin	Name	IN/OUT	Remark
1	Power	IN	5V ~ 13.2V Input Range
2	Trigger	IN	Opto-Isolated Trigger Input+(2.5V~24V)
3	GPIO1	IN/OUT	General Purpose I/O 1
4	GPIO2	IN/OUT	General Purpose I/O 2
5	Trigger	IN	Opto-Isolated Trigger Input-
6	GND	IN	

### Back Panel

Pin	Name	Remark
1	USB3.1 Gen.1 Connector	Type Micro-B
2	Power & I/O Connector	6Pin Circular
3	LED Indicator	LED

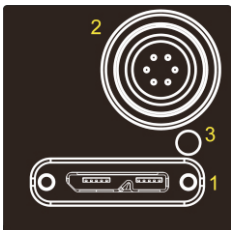

### Dimension (Unit : mm)

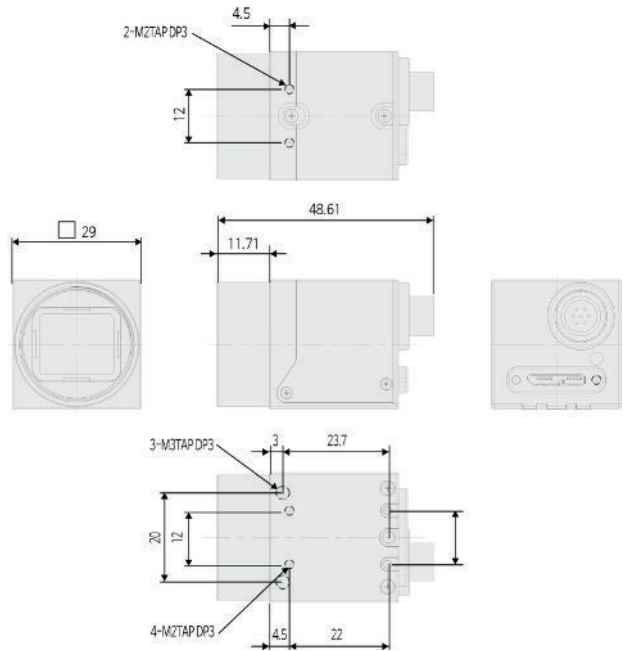

### Download (File name)

ex) SDK download:

CREVIS Site ▶ Search window ▶

SDK : MCamU\_Basic.zip

Model	MU-A040M-523	MU-A040K-523
Sensor	Sony CMOS Pregius IMX287	
Sensor size	1/2.9"	
Pixel size (μm)	6.9 x 6.9	
Resolution	728 x 544	
Frame Rate (Max.)	523fps	
Color / Mono	Mono Chrome	Color
Scanning method	Full / ROI(Horizontal+Vertical) / Reverse(X,Y,All)	
Synchronization	Internal (Freerun), External, Software trigger via PC	
Trigger mode	Fixed shutter, Pulse width shutter	
Shutter	Global	
Shutter speed	1us ~ 3sec (Exposure Offset : 별도)	
Gain	Analog : 0dB ~ 27.6dB (1x ~ 24x) Digital : 0dB ~ 18dB (1x ~ 8x)	
Black level	Analog : 0 ~ 255 (8bit) / Digital : 0 ~ 4095 (12bit)	
Gamma / LUT	Gamma Correction, Adjustable LUT (12bit to 12bit)	
Auto white balance	Off / Once / Continuous (Only Color Models)	
Auto gain / exposure	Off / Once / Continuous	
Interface	USB3.1 Gen. 1 (USB3 Vision Standard 1.1)	
Pixel Data Format	Mono8/10/12	Mono8/10/12, BayerRG8/10/12, RGB8
SNR	35dB	
Function control	GainAuto, ExposureAuto, BalanceWhiteAuto, Acquisition Frame Rate(Adjustable), Line Debouncer, Defective Pixel Correction, Shading Correction(FFC), Color Transformation Control, Noise Reduction	
Lens mount	C mount	
Power requirements	DC 5V ~ 13.2V ± 10% or USB3 Bus	
Consumption	DC	< 3.3W
	USB	< 3.3W (Max.)
Weight	< 44g	
Dimension	29 x 29 x 29 mm (without mount)	
Temperature	0°C ~ 40°C (Operating) / -20°C ~ 60°C (Storage)-(with <20~80% RH)	
Vibration / Shock	98m/s <sup>2</sup> (10G) / 196m/s <sup>2</sup> (20.0G)	
Standard compliancy	CE (EN61326-1:2013년); Class A)	
Conformity	RoHS, WEEE, UL	
Warranty	3 years	

Model	MU-A160M-226	MU-A160K-226
Sensor	Sony CMOS Pregius IMX273	
Sensor size	1/2.9"	
Pixel size (μm)	3.45 x 3.45	
Resolution	1456 x 1088	
Frame Rate (Max.)	226fps	
Color / Mono	Mono Chrome	Color
Scanning method	Full / ROI(Horizontal+Vertical) / Reverse(X,Y,All) / Decimation(X,Y,All) / Binning (Only Mono Model)	
Synchronization	Internal (Freerun), External, Software trigger via PC	
Trigger mode	Fixed shutter, Pulse width shutter	
Shutter	Global	
Shutter speed	1us ~ 3sec (Exposure Offset : 별도)	
Gain	Analog : 0dB ~ 27.6dB (1x ~ 24x) Digital : 0dB ~ 18dB (1x ~ 8x)	
Black level	Analog : 0 ~ 255 (8bit) / Digital : 0 ~ 4095 (12bit)	
Gamma / LUT	Gamma Correction, Adjustable LUT (12bit to 12bit)	
Auto white balance	Off / Once / Continuous (Only Color Models)	
Auto gain / exposure	Off / Once / Continuous	
Interface	USB3.1 Gen. 1 (USB3 Vision Standard 1.1)	
Pixel Data Format	Mono8/10/12	Mono8/10/12, BayerRG8/10/12, RGB8
SNR	38dB	
Function control	GainAuto, ExposureAuto, BalanceWhiteAuto, Acquisition Frame Rate(Adjustable), Line Debouncer, Defective Pixel Correction, Shading Correction(FFC), Color Transformation Control, Noise Reduction	
Lens mount	C mount	
Power requirements	DC 5V ~ 13.2V ± 10% or USB3 Bus	
Consumption	DC	< 3.2W
	USB	< 3.7W (Max.)
Weight	< 44g	
Dimension	29 x 29 x 29 mm (without mount)	
Temperature	0°C ~ 40°C (Operating) / -20°C ~ 60°C (Storage)-(with <20~80% RH)	
Vibration / Shock	98m/s <sup>2</sup> (10G) / 196m/s <sup>2</sup> (20.0G)	
Standard compliancy	CE (EN61326-1:2013년); Class A)	
Conformity	RoHS, WEEE, UL	
Warranty	3 years	

Model	MU-A320M-118	MU-A320K-118
Sensor	Sony CMOS Pregius IMX252	
Sensor size	1/1.8"	
Pixel size ( $\mu\text{m}$ )	3.45 x 3.45	
Resolution	2064 x 1544	
Frame Rate (Max.)	118fps	
Color / Mono	Mono Chrome	Color
Scanning method	Full / ROI(Horizontal+Vertical) / Reverse(X,Y,All) / Decimation(X,Y,All) / Binning (Only Mono Model)	
Synchronization	Internal (Freerun), External, Software trigger via PC	
Trigger mode	Fixed shutter, Pulse width shutter	
Shutter	Global	
Shutter speed	1us ~ 3sec (Exposure Offset : 별도)	
Gain	Analog : 0dB ~ 27.6dB (1x ~ 24x) Digital : 0dB ~ 18dB (1x ~ 8x)	
Black level	Analog : 0 ~ 255 (8bit) / Digital : 0 ~ 4095 (12bit)	
Gamma / LUT	Gamma Correction, Adjustable LUT (12bit to 12bit)	
Auto white balance	Off / Once / Continuous (Only Color Models)	
Auto gain / exposure	Off / Once / Continuous	
Interface	USB3.1 Gen. 1 (USB3 Vision Standard 1.1)	
Pixel Data Format	Mono8/10/12	Mono8/10/12, BayerRG8/10/12, RGB8
SNR	36dB	
Function control	GainAuto, ExposureAuto, BalanceWhiteAuto, Acquisition Frame Rate(Adjustable), Line Debouncer, Defective Pixel Correction, Shading Correction(FFC), Color Transformation Control, Noise Reduction	
Lens mount	C mount	
Power requirements	DC 5V ~ 13.2V $\pm$ 10% or USB3 Bus	
Consumption	DC	< 4.0W
	USB	< 4.7W (Max.)
Weight	< 44g	
Dimension	29 x 29 x 29 mm (without mount)	
Temperature	0°C ~ 40°C (Operating) / -20°C ~ 60°C (Storage)-(with <20~80% RH)	
Vibration / Shock	98m/s <sup>2</sup> (10G) / 196m/s <sup>2</sup> (20.0G)	
Standard compliancy	CE (EN61326-1:2013년); Class A)	
Conformity	RoHS, WEEE, UL	
Warranty	3 years	

Model	MU-A320M-55	MU-A320K-55
Sensor	Sony CMOS Pregius IMX265	
Sensor size	1/1.8"	
Pixel size (μm)	3.45 x 3.45	
Resolution	2064 x 1544	
Frame Rate (Max.)	55fps	
Color / Mono	Mono Chrome	Color
Scanning method	Full / ROI(Horizontal+Vertical) / Reverse(X,Y,All) / Decimation(X,Y,All)	
Synchronization	Internal (Freerun), External, Software trigger via PC	
Trigger mode	Fixed shutter, Pulse width shutter	
Shutter	Global	
Shutter speed	1us ~ 3sec (Exposure Offset : 별도)	
Gain	Analog : 0dB ~ 27.6dB (1x ~ 24x) Digital : 0dB ~ 18dB (1x ~ 8x)	
Black level	Analog : 0 ~ 255 (8bit) / Digital : 0 ~ 4095 (12bit)	
Gamma / LUT	Gamma Correction, Adjustable LUT (12bit to 12bit)	
Auto white balance	Off / Once / Continuous (Only Color Models)	
Auto gain / exposure	Off / Once / Continuous	
Interface	USB3.1 Gen. 1 (USB3 Vision Standard 1.1)	
Pixel Data Format	Mono8/10/12	Mono8/10/12, BayerRG8/10/12, RGB8
SNR	39dB	
Function control	GainAuto, ExposureAuto, BalanceWhiteAuto, Acquisition Frame Rate(Adjustable), Line Debouncer, Defective Pixel Correction, Shading Correction(FFC), Color Transformation Control, Noise Reduction	
Lens mount	C mount	
Power requirements	DC 5V ~ 13.2V ± 10% or USB3 Bus	
Consumption	DC	< 3.1W
	USB	< 3.4W (Max.)
Weight	< 44g	
Dimension	29 x 29 x 29 mm (without mount)	
Temperature	0°C ~ 40°C (Operating) / -20°C ~ 60°C (Storage)-(with <20~80% RH)	
Vibration / Shock	98m/s <sup>2</sup> (10G) / 196m/s <sup>2</sup> (20.0G)	
Standard compliancy	CE (EN61326-1:2013년); Class A)	
Conformity	RoHS, WEEE, UL	
Warranty	3 years	

Model	MU-A500M-35	MU-A500K-35
Sensor	Sony CMOS Pregius IMX264	
Sensor size	2/3"	
Pixel size ( $\mu\text{m}$ )	3.45 x 3.45	
Resolution	2464 x 2056	
Frame Rate (Max.)	35fps	
Scanning method	Full / ROI(Horizontal+Vertical) / Reverse(X,Y,All) / Decimation(X,Y,All)	
Synchronization	Internal (Freerun), External, Software trigger via PC	
Trigger mode	Fixed shutter, Pulse width shutter	
Shutter	Global	
Shutter speed	1us ~ 3sec (Exposure Offset : 별도)	
Gain	Analog : 0dB ~ 27.6dB (1x ~ 24x) Digital : 0dB ~ 18dB (1x ~ 8x)	
Black level	Analog : 0 ~ 255 (8bit) / Digital : 0 ~ 4095 (12bit)	
Gamma / LUT	Gamma Correction, Adjustable LUT (12bit to 12bit)	
Auto white balance	Off / Once / Continuous (Only Color Models)	
Auto gain / exposure	Off / Once / Continuous	
Interface	USB3.1 Gen. 1 (USB3 Vision Standard 1.1)	
Pixel Data Format	Mono : Mono8/10/12	Color : Mono8/10/12, BayerRG8/10/12, RGB8
SNR	38dB	
Function control	GainAuto, ExposureAuto, BalanceWhiteAuto, Acquisition Frame Rate(Adjustable), Line Debouncer, Defective Pixel Correction, Shading Correction(FFC), Color Transformation Control, Noise Reduction	
Lens mount	C mount	
Power requirements	DC 5V ~ 13.2V $\pm$ 10% or USB3 Bus	
Consumption	DC	< 3.2W
	USB	< 3.4W (Max.)
Weight	< 44g	
Dimension	29 x 29 x 29 mm (without mount)	
Temperature	0°C ~ 40°C (Operating) / -20°C ~ 60°C (Storage)-(with <20~80% RH)	
Vibration / Shock	98m/s <sup>2</sup> (10G) / 196m/s <sup>2</sup> (20.0G)	
Standard compliancy	CE (EN61326-1:2013년): Class A)	
Conformity	RoHS, WEEE, UL	
Warranty	3 years	

Model	MU-A121M-23	MU-A121K-23
Sensor	Sony CMOS Pregius IMX304	
Sensor size	1.1"	
Pixel size (μm)	3.45 x 3.45	
Resolution	4112 x 3008	
Frame Rate (Max.)	23fps	
Color / Mono	Mono Chrome	Color
Scanning method	Full / ROI(Horizontal+Vertical) / Reverse(X,Y,All) / Decimation(X,Y,All)	
Synchronization	Internal (Freerun), External, Software trigger via PC	
Trigger mode	Fixed shutter, Pulse width shutter	
Shutter	Global	
Shutter speed	1us ~ 3sec (Exposure Offset : 별도)	
Gain	Analog : 0dB ~ 27.6dB (1x ~ 24x) Digital : 0dB ~ 18dB (1x ~ 8x)	
Black level	Analog : 0 ~ 255 (8bit) / Digital : 0 ~ 4095 (12bit)	
Gamma / LUT	Gamma Correction, Adjustable LUT (12bit to 12bit)	
Auto white balance	Off / Once / Continuous (Only Color Models)	
Auto gain / exposure	Off / Once / Continuous	
Interface	USB3.1 Gen. 1 (USB3 Vision Standard 1.1)	
Pixel Data Format	Mono8/10/12	Mono8/10/12, BayerRG8/10/12, RGB8
SNR	38dB	
Function control	GainAuto, ExposureAuto, BalanceWhiteAuto, Acquisition Frame Rate(Adjustable), Line Debouncer, Defective Pixel Correction, Shading Correction(FFC), Color Transformation Control, Noise Reduction	
Lens mount	C mount	
Power requirements	DC 5V ~ 13.2V ± 10% or USB3 Bus	
Consumption	DC	< 3.6W
	USB	< 3.9W (Max.)
Weight	< 44g	
Dimension	29 x 29 x 29 mm (without mount)	
Temperature	0°C ~ 40°C (Operating) / -20°C ~ 60°C (Storage)-(with <20~80% RH)	
Vibration / Shock	98m/s <sup>2</sup> (10G) / 196m/s <sup>2</sup> (20.0G)	
Standard compliancy	CE (EN61326-1:2013년); Class A)	
Conformity	RoHS, WEEE, UL	
Warranty	3 years	

Model	MU-A121R-31	MU-A121L-31
Sensor	Sony CMOS Starvis IMX226	
Sensor size	1/1.7"	
Pixel size ( $\mu\text{m}$ )	1.85 x 1.85	
Resolution	4072 x 3046	
Frame Rate (Max.)	30fps	
Color / Mono	Mono Chrome	Color
Scanning method	Full / ROI(Horizontal+Vertical) / Reverse(X,Y,All)	
Synchronization	Internal (Freerun), External, Software trigger via PC	
Trigger mode	Fixed shutter, Pulse width shutter	
Shutter	Rolling, Global Reset	
Shutter speed	99us ~ 3sec	
Gain	Analog : 0dB ~ 27.6dB (1x ~ 22.5x) Digital : 0dB ~ 18dB (1x ~ 8x)	
Black level	Analog : 0 ~ 255 (8bit) / Digital : 0 ~ 4095 (12bit)	
Gamma / LUT	Gamma Correction, Adjustable LUT (12bit to 12bit)	
Auto white balance	Off / Once / Continuous (Only Color Models)	
Auto gain / exposure	Off / Once / Continuous	
Interface	USB3.1 Gen. 1 (USB3 Vision Standard 1.1)	
Pixel Data Format	Mono8/10/12	Mono8/10/12, BayerRG8/10/12, RGB8
SNR	36dB	
Function control	GainAuto, ExposureAuto, BalanceWhiteAuto, Acquisition Frame Rate(Adjustable), Line Debouncer, Defective Pixel Correction, Shading Correction(FFC), Color Transformation Control, Noise Reduction	
Lens mount	C mount	
Power requirements	DC 5V ~ 13.2V $\pm$ 10% or USB3 Bus	
Consumption	DC	< 3.6W
	USB	< 3.8W (Max.)
Weight	< 44g	
Dimension	29 x 29 x 29 mm (without mount)	
Temperature	0°C ~ 40°C (Operating) / -20°C ~ 60°C (Storage)-(with <20~80% RH)	
Vibration / Shock	98m/s <sup>2</sup> (10G) / 196m/s <sup>2</sup> (20.0G)	
Standard compliancy	CE (EN61326-1:2013년); Class A)	
Conformity	RoHS, WEEE, UL	
Warranty	3 years	

Model	MU-A201R-18	MU-A201L-18
Sensor	Sony CMOS Starvis IMX183	
Sensor size	1"	
Pixel size ( $\mu\text{m}$ )	2.4 x 2.4	
Resolution	5496 x 3672	
Frame Rate (Max.)	18fps	
Color / Mono	Mono Chrome	Color
Scanning method	Full / ROI(Horizontal+Vertical) / Reverse(X,Y,All)	
Synchronization	Internal (Freerun), External, Software trigger via PC	
Trigger mode	Fixed shutter, Pulse width shutter	
Shutter	Rolling, Global Reset	
Shutter speed	141us ~ 3sec	
Gain	Analog : 0dB ~ 27.6dB (1x ~ 22.5x) Digital : 0dB ~ 18dB (1x ~ 8x)	
Black level	Analog : 0 ~ 255 (8bit) / Digital : 0 ~ 4095 (12bit)	
Gamma / LUT	Gamma Correction, Adjustable LUT (12bit to 12bit)	
Auto white balance	Off / Once / Continuous	
Auto gain / exposure	Off / Once / Continuous	
Interface	USB3.1 Gen. 1 (USB3 Vision Standard 1.1)	
Pixel Data Format	Mono8/10/12	Mono8/10/12, BayerRG8/10/12, RGB8
SNR	41dB	
Function control	GainAuto, ExposureAuto, BalanceWhiteAuto, Acquisition Frame Rate(Adjustable), Line Debouncer, Defective Pixel Correction, Shading Correction(FFC), Color Transformation Control, Noise Reduction	
Lens mount	C mount	
Power requirements	DC 5V ~ 13.2V $\pm$ 10% or USB3 Bus	
Consumption	DC	< 4.0W
	USB	< 4.0W (Max.)
Weight	< 44g	
Dimension	29 x 29 x 29 mm (without mount)	
Temperature	0°C ~ 40°C (Operating) / -20°C ~ 60°C (Storage)-(with <20~80% RH)	
Vibration / Shock	98m/s <sup>2</sup> (10G) / 196m/s <sup>2</sup> (20.0G)	
Standard compliancy	CE (EN61326-1:2013년); Class A	
Conformity	RoHS, WEEE, UL	
Warranty	3 years	

## USB2.0 Cameras



### Key Features

Mini-size CCD/ CMOS USB 2.0 Camera  
 HALCON, Labview, Mil  
 Camera Standard  
 - Genlcam  
 Plug & Play  
 Trigger input range : +5V~24V(Photo coupler)

### Dimension (Unit : mm)

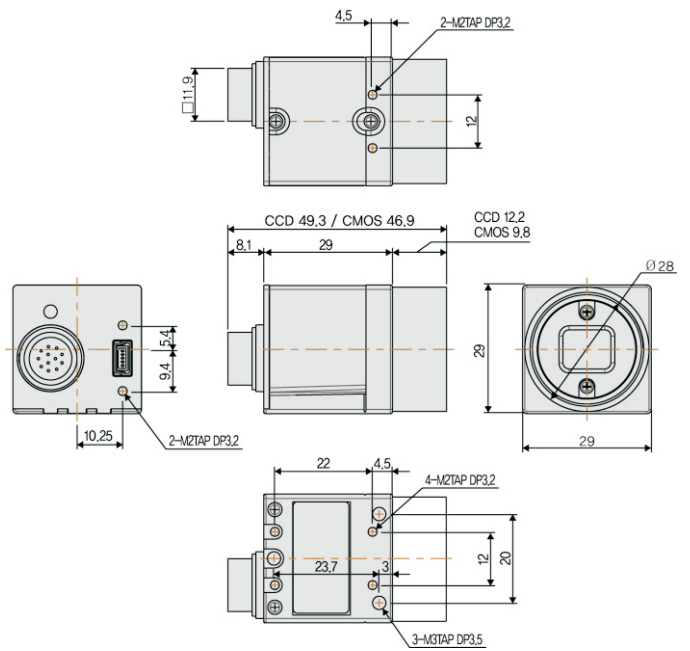

### Pin map

12pin Connector

Pin No.	Name	IN/OUT	Remark
1	Strobe-	GND1	
2	Power	IN	USB Bus+5Vdc
3	GND	IN	
4	NC	-	
5	USB D-	IN/OUT	
6	USB D+	IN/OUT	
7	GND	IN	
8	Trigger+	IN	Isolation (50V)
9	Trigger-	GND2	
10	Strobe+	OUT	
11	GND	IN	Open Collector
12	GND	IN	



### Download (File name)

ex) SDK download:

CREVIS Site ▶ Search window ▶

SDK : M2CamU\_Basic.zip

Model (Mono)	MV-BW35U
Sensor size	1/3"
Image sensor	CMOS
Resolution	752 x 480
Pixel size (μm)	6.0 x 6.0
Frame Rate (Max.)	60fps
Scanning method	Vertical, Horizontal / Binning (Only Mono Models)
Synchronization	Freerun, Software Trigger, External Trigger
Trigger modes	Timed
Shutter	Global
Shutter speed	100μs~16.6ms
Pixel data formats	Mono8/10 Mono8, RGB8packed, Bayer8
Gain	0dB ~ 12dB
Gamma	1, 0.45, 0.7, LUT
Exposure control	Programmable via the camera API, External trigger signal
Interface	USB 2.0
Lens mount	C mount
Weight	< 46g
Dimension	29 x 29 x 29 mm (without mount)
Temperature	0°C ~ 45°C (Operating) / -20°C ~ 60°C (with<20~80%RH) (Storage)
Vibration / Shock	98m/s <sup>2</sup> (10G) / 490m/s <sup>2</sup> (50G)
Power consumption	< 0.8W
Power requirements	+5V Via USB Cable (Mini B or Circular 12pin)
Conformity	CE, RoHS
Warranty	3 years

(Color)	MV-CW35U
Sensor size	1/3"
Image sensor	CMOS
Resolution	752 x 480
Pixel size (μm)	6.0 x 6.0
Frame Rate (Max.)	60fps
Scanning method	Vertical, Horizontal / Binning (Only Mono Models)
Synchronization	Freerun, Software Trigger, External Trigger
Trigger modes	Timed
Shutter	Global
Shutter speed	100μs~16.6ms
Pixel data formats	Mono8/10 Mono8, RGB8packed, Bayer8
Gain	0dB ~ 12dB
Gamma	1, 0.45, 0.7, LUT
Exposure control	Programmable via the camera API, External trigger signal
Interface	USB 2.0
Lens mount	C mount
Weight	< 46g
Dimension	29 x 29 x 29 mm (without mount)
Temperature	0°C ~ 45°C (Operating) / -20°C ~ 60°C (with<20~80%RH) (Storage)
Vibration / Shock	98m/s <sup>2</sup> (10G) / 490m/s <sup>2</sup> (50G)
Power consumption	< 0.8W
Power requirements	+5V Via USB Cable (Mini B or Circular 12pin)
Conformity	CE, RoHS
Warranty	3 years

## Analog Cameras



### Key Features

Mini-size CCD Analog camera  
 Trigger input range : +3V~5V  
 EIA camera(MV-BE20A, MA-D037E)  
 High Rates Scanning(HRS mode)

### Dimension (Unit : mm)

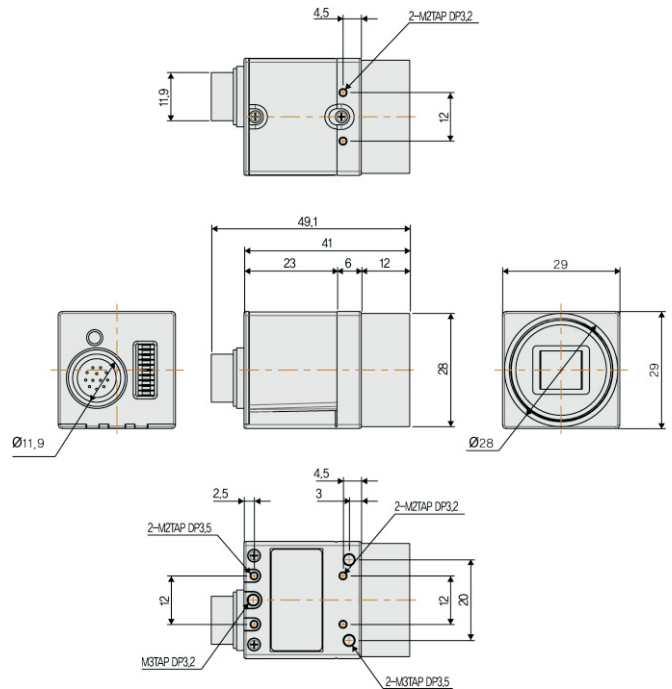

### Pin map

12pin Connector

Pin No.	Name	IN/OUT	Description
1	GND	IN	Power GND
2	PWR	IN	10.8V~13.2V Input Range
3	GND	IN	Power GND
4	Video Signal	OUT	Video Output
5	GND	IN	HD GND
6	HD	IN/OUT	Horizontal SYNC
7	VD	IN/OUT	Vertical SYNC
8	GND	IN	VD GND
9	HRS	IN	Pixel clock output
10	WEN	OUT	WEN Output
11	Trigger	IN	Trigger Input
12	GND	IN	Trigger GND



### Download (File name)

ex) SDK download:

CREVIS Site ▶ Search window ▶

- Camfile : analog\_matrox.zip
- analog\_cognex.zip
- analog\_Coreco-Dalsa.zip
- analog\_euresys.zip

Model (Mono)	MA-D200B
Sensor size	1/1.8"
Image sensor	CCD
Resolution	1620 x 1220
Pixel size (μm)	4.4 x 4.4
Frame Rate (Max.)	15fps
Interface	1 Vpp Analog Composite Signal
Binning modes	Vertical
Synchronization	Internal, External Trigger
Sync level	Input : 3~5 Vpp, TTL input, Output : 5V Level
Partial scan	Full : 1220 Lines/15fps 1/2 : 550 Lines/30fps 1/4 : 211 Lines/60fps
Horizontal scan frequency	Horizontal : 18.75KHz Vertical : 14.98Hz
Trigger modes	Edge preset mode(fixed shutter), Pulse width
Shutter	Global
Shutter speed	Off, 1/125, 1/250, 1/500, 1/1000, 1/2000, 1/4000, 1/10000sec
Minimum illumination	1.0 lx, F1.4, Gain MAX, without IR cut filter
Horizontal resolution	1220 TV lines (Min)
S/N ratio	34dB
Optical axis accuracy	Image Center ±0.1mm
Gain	0dB ~ 12dB
Gamma / LUT	1.0 (fixed)
Exposure trigger control	Positive and rising mode
Lens mount	C mount
Weight	< 44g
Dimension	29 x 29 x 29 mm (without mount)
Temperature	0°C ~ 45°C (Operating) / -20°C ~ 60°C (with<20~80%RH) (Storage)
Power consumption	< 1.6W
Power requirements	12VDC ± 10%, PoE (Power over Ethernet 802.3af compliant)
Conformity	CE, RoHS, WEEE
Warranty	3 years

Model (Mono)	MA-D210B
Sensor size	1/3"
Image sensor	CCD
Resolution	1920 x 1080
Pixel size (μm)	2.8 x 2.8
Frame Rate (Max.)	15fps
Interface	1 Vpp Analog Composite Signal
Binning modes	Vertical
Synchronization	Internal, External Trigger
Sync level	Input : 3~5 Vpp, TTL input, Output : 5V Level
Partial scan	Full : 1080 Lines/15fps 1/2 : 493 Lines/30fps 1/4 : 198 Lines/60fps
Horizontal scan frequency	Horizontal : 16.514KHz Vertical : 15.01Hz
Trigger modes	Edge preset mode(fixed shutter), Pulse width
Shutter	Global
Shutter speed	Off, 1/125, 1/250, 1/500, 1/1000, 1/2000, 1/4000, 1/10000sec
Minimum illumination	1.0 lx, F1.4, Gain MAX, without IR cut filter
Horizontal resolution	1080 TV lines (Min)
S/N ratio	34dB
Optical axis accuracy	Image Center ±0.1mm
Gain	0dB ~ 12dB
Gamma / LUT	1.0 (fixed)
Exposure trigger control	Positive and rising mode
Lens mount	C mount
Weight	< 44g
Dimension	29 x 29 x 29 mm (without mount)
Temperature	0°C ~ 45°C (Operating) / -20°C ~ 60°C (with<20~80%RH) (Storage)
Power consumption	< 1.7W
Power requirements	12VDC ± 10%, PoE (Power over Ethernet 802.3af compliant)
Conformity	CE, RoHS, WEEE
Warranty	3 years

Model (Mono)	MA-D030B
Sensor size	1/3"
Image sensor	CCD
Resolution	660 x 494
Pixel size (μm)	7.4 x 7.4
Frame Rate (Max.)	70fps
Interface	1 Vpp Analog Composite Signal
Binning modes	Vertical
Synchronization	Internal, External Trigger
Sync level	Input : 3~5 Vpp, TTL input, Output : 5V Level
Partial scan	Full : 520 Lines/70fps 1/2 : 219 Lines/140fps 1/4 : 83 Lines/280fps
Horizontal scan frequency	Horizontal : 35.885KHz Vertical : 70.088Hz
Trigger modes	Edge preset mode(fixed shutter), Pulse width
Shutter	Global
Shutter speed	Off, 1/200, 1/500, 1/1000, 1/2000, 1/4000, 1/10000, 1/20000sec
Minimum illumination	1.0 lx, F1.4, Gain MAX, without IR cut filter
Horizontal resolution	520 TV lines (Min)
S/N ratio	35dB
Optical axis accuracy	Image Center ±0.1mm
Gain	0dB ~ 12dB
Gamma / LUT	1.0 (fixed)
Exposure trigger control	Positive and rising mode
Lens mount	C mount
Weight	< 44g
Dimension	29 x 29 x 29 mm (without mount)
Temperature	0°C ~ 45°C (Operating) / -20°C ~ 60°C (with<20~80%RH) (Storage)
Power consumption	< 1.4W
Power requirements	12VDC ± 10%
Conformity	CE, RoHS, WEEE
Warranty	3 years

Model (Mono)	MA-D037E
Sensor size	1/3"
Image sensor	CCD
Resolution	768 x 494
Pixel size (μm)	6.4 x 7.5
Frame Rate (Max.)	30fps
Interface	1 Vpp Analog Composite Signal
Binning modes	Vertical
Synchronization	Internal, External Trigger
Sync level	Input : 3~5 Vpp, TTL input, Output : 5V Level
Partial scan	Double speed mode 60fps - -
Horizontal scan frequency	Horizontal : 15.734KHz Vertical : 59.94Hz
Trigger modes	Edge preset mode(fixed shutter), Pulse width
Shutter	Global
Shutter speed	Off, 1/125, 1/250, 1/500, 1/1000, 1/2000, 1/4000, 1/10000sec
Minimum illumination	1.0 lx, F1.4, Gain MAX, without IR cut filter
Horizontal resolution	570 TV lines (Min)
S/N ratio	56dB
Optical axis accuracy	Image Center ±0.1mm
Gain	0dB ~ 12dB
Gamma / LUT	1.0 (fixed)
Exposure trigger control	Positive and rising mode
Lens mount	C mount
Weight	< 44g
Dimension	29 x 29 x 29 mm (without mount)
Temperature	0°C ~ 45°C (Operating) / -20°C ~ 60°C (with<20~80%RH) (Storage)
Power consumption	< 1.6W
Power requirements	12VDC ± 10%
Conformity	CE, RoHS, WEEE
Warranty	3 years

Model (Mono)	MV-BX30A
Sensor size	1/3"
Image sensor	CCD
Resolution	1024 x 772
Pixel size (μm)	4.65 x 4.65
Max frame rate	30fps
Interface	1 Vpp Analog Composite Signal
Binning modes	Vertical
Synchronization	Internal, External Trigger
Sync level	Input : 3~5 Vpp, TTL input, Output : 5V Level
Partial scan	Full : 768 Lines/30fps 1/2 : 353 Lines/60fps 1/3 : 218 Lines/90fps 1/4 : 151 Lines/120fps
Horizontal scan frequency	Horizontal : 23.6KHz Vertical : 30Hz
Trigger modes	Edge preset mode(fixed shutter), Pulse width
Shutter	Global
Shutter speed	Off, 1/125, 1/250, 1/500, 1/1000, 1/2000, 1/4000, 1/10000sec
Minimum illumination	2.0 lx (F1.4, 50 IRE, 1/30sec)
Horizontal resolution	768 TV lines (Min)
S/N ratio	56dB
Optical axis accuracy	Image Center ±0.1mm
Gain	Manual (0dB ~ 12dB)
Gamma	1.0 (fixed)
Exposure trigger control	Positive and rising mode
Lens mount	C mount
Weight	< 44g
Dimension	29 x 29 x 29 mm (without mount)
Temperature	0°C ~ 45°C (Operating) / -20°C ~ 60°C (with<20~80%RH) (Storage)
Power consumption	< 1.8W
Power requirements	12VDC ± 10%
Conformity	CE, RoHS
Warranty	3 years

### MV-D037E

#### Mode Switch

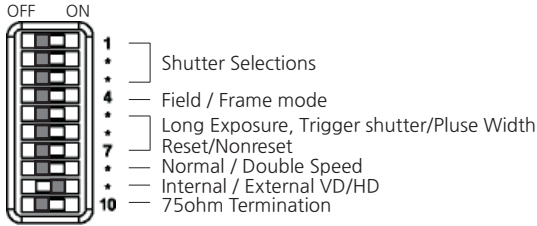

#### Normal Shutter

OFF	1/125	1/250	1/500	1/1000	1/2000	1/4000	1/10000
1 <input type="checkbox"/>	1 <input type="checkbox"/>	1 <input type="checkbox"/>	1 <input type="checkbox"/>	1 <input type="checkbox"/>	1 <input type="checkbox"/>	1 <input type="checkbox"/>	1 <input type="checkbox"/>
2 <input type="checkbox"/>	2 <input type="checkbox"/>	2 <input type="checkbox"/>	2 <input type="checkbox"/>	2 <input type="checkbox"/>	2 <input type="checkbox"/>	2 <input type="checkbox"/>	2 <input type="checkbox"/>
3 <input type="checkbox"/>	3 <input type="checkbox"/>	3 <input type="checkbox"/>	3 <input type="checkbox"/>	3 <input type="checkbox"/>	3 <input type="checkbox"/>	3 <input type="checkbox"/>	3 <input type="checkbox"/>

\* Normal Shutter is automatically set up 1/100 second when shutter off in trigger Shutter mode.

#### Mode setting

Standard	Trigger operation				Long exposure
	Trigger shutter (Reset)	Trigger shutter (Nonreset)	Pulse width (Reset)	Pulse width (Nonreset)	
5 <input type="checkbox"/>	5 <input type="checkbox"/>	5 <input type="checkbox"/>	5 <input type="checkbox"/>	5 <input type="checkbox"/>	5 <input type="checkbox"/>
6 <input type="checkbox"/>	6 <input type="checkbox"/>	6 <input type="checkbox"/>	6 <input type="checkbox"/>	6 <input type="checkbox"/>	6 <input type="checkbox"/>
7 <input type="checkbox"/>	7 <input type="checkbox"/>	7 <input type="checkbox"/>	7 <input type="checkbox"/>	7 <input type="checkbox"/>	7 <input type="checkbox"/>
Field/Frame		Double Speed	External HD/VD	Termination Resistor	
Field	Frame			75ohm	Open
4 <input type="checkbox"/>	4 <input type="checkbox"/>	8 <input type="checkbox"/>	9 <input type="checkbox"/>	10 <input type="checkbox"/>	10 <input type="checkbox"/>

### MA-D200B/D210B/D030B

#### Mode Switch

PIN NO.	Name	Description
1	Shutter speed	OFF(1/15sec) ~ 1/10,000sec
2		
3		
4	Trigger Shutter mode	Normal/Fixed/PWC 1,2,3
5		
6	HRS Scan Mode	Full/Binning/1/2, 1/4 Partial
7		
8	Full Scan Enable	HRS Enable / Full Scan Enable
9	External Sync	HD/VD Input/Output
10	Trigger Polarity	Positive / Negative

#### Shutter speed

1 : MA-D130B    2 : MA-D200B  
3 : MA-D210B    4 : MA-D030B

	OFF	1/100	1/200	1/500	1/1000	1/2000	1/4000	1/10000
1	<input type="checkbox"/>	<input type="checkbox"/>	<input type="checkbox"/>	<input type="checkbox"/>	<input type="checkbox"/>	<input type="checkbox"/>	<input type="checkbox"/>	<input type="checkbox"/>
2	<input type="checkbox"/>	<input type="checkbox"/>	<input type="checkbox"/>	<input type="checkbox"/>	<input type="checkbox"/>	<input type="checkbox"/>	<input type="checkbox"/>	<input type="checkbox"/>
3	<input type="checkbox"/>	<input type="checkbox"/>	<input type="checkbox"/>	<input type="checkbox"/>	<input type="checkbox"/>	<input type="checkbox"/>	<input type="checkbox"/>	<input type="checkbox"/>
4	<input type="checkbox"/>	<input type="checkbox"/>	<input type="checkbox"/>	<input type="checkbox"/>	<input type="checkbox"/>	<input type="checkbox"/>	<input type="checkbox"/>	<input type="checkbox"/>
	9.99ms	5.0ms	1.99ms	984.10us	482.50us	231.70us	92.37us	36.63us

\* Trigger mode가 Normal 또는 Fixed Mode일때 Shutter 설정값임.

### MV-BX30A

#### Mode Switch

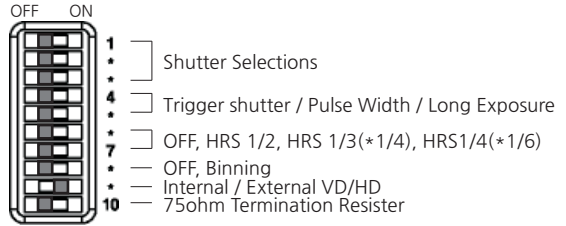

#### Normal Shutter(unit:second)

OFF	1/125	1/250	1/500	1/1000	1/2000	1/4000	1/10000
1 <input type="checkbox"/>	1 <input type="checkbox"/>	1 <input type="checkbox"/>	1 <input type="checkbox"/>	1 <input type="checkbox"/>	1 <input type="checkbox"/>	1 <input type="checkbox"/>	1 <input type="checkbox"/>
2 <input type="checkbox"/>	2 <input type="checkbox"/>	2 <input type="checkbox"/>	2 <input type="checkbox"/>	2 <input type="checkbox"/>	2 <input type="checkbox"/>	2 <input type="checkbox"/>	2 <input type="checkbox"/>
3 <input type="checkbox"/>	3 <input type="checkbox"/>	3 <input type="checkbox"/>	3 <input type="checkbox"/>	3 <input type="checkbox"/>	3 <input type="checkbox"/>	3 <input type="checkbox"/>	3 <input type="checkbox"/>

\* Normal Shutter is automatically set up 1/100 second when shutter off in trigger Shutter mode.

#### Mode Setting

External Trigger operation			Long Exposure	Binning	
OFF	Trigger Shutter	Pulse width		OFF	ON
4 <input type="checkbox"/>	4 <input type="checkbox"/>	4 <input type="checkbox"/>	4 <input type="checkbox"/>	8 <input type="checkbox"/>	8 <input type="checkbox"/>
5 <input type="checkbox"/>	5 <input type="checkbox"/>	5 <input type="checkbox"/>	5 <input type="checkbox"/>		
HRS				External HD/VD	Termination Resistor 75ohm
OFF	1/2	1/3(*1/4)	1/4(*1/6)		
6 <input type="checkbox"/>	6 <input type="checkbox"/>	6 <input type="checkbox"/>	6 <input type="checkbox"/>	9 <input type="checkbox"/>	10 <input type="checkbox"/>
7 <input type="checkbox"/>	7 <input type="checkbox"/>	7 <input type="checkbox"/>	7 <input type="checkbox"/>		

#### Trigger Shutter mode

Normal (Freerun)	External Trigger Operation		
	Fixed	PWC1	PWC2/3
4 <input type="checkbox"/>	4 <input type="checkbox"/>	4 <input type="checkbox"/>	4 <input type="checkbox"/>
5 <input type="checkbox"/>	5 <input type="checkbox"/>	5 <input type="checkbox"/>	5 <input type="checkbox"/>

- Fixed : Trigger Sync. Reset Mode  
- PWC1 : Trigger Sync Reset Mode  
- PWC2 : Trigger Sync. Non-Reset (VD Reset) Mode  
- PWC3 : Long Exposure Mode  
(Ext.Sync Mode가 'ON'이고 SW-Shutter speed가 'OFF' 일때만 설정됨)

#### HRS Scan Mode

Scan Mode			
FULL	Binning	1/2 Partial	1/4 Partial
6 <input type="checkbox"/>	6 <input type="checkbox"/>	6 <input type="checkbox"/>	6 <input type="checkbox"/>
7 <input type="checkbox"/>	7 <input type="checkbox"/>	7 <input type="checkbox"/>	7 <input type="checkbox"/>

#### Etc

Full Scan Enable		External Sync		Trig Polarity	
OFF	ON	OFF	ON	Positive	Negative
8 <input type="checkbox"/>	8 <input type="checkbox"/>	9 <input type="checkbox"/>	9 <input type="checkbox"/>	10 <input type="checkbox"/>	10 <input type="checkbox"/>

## Line Scan Cameras

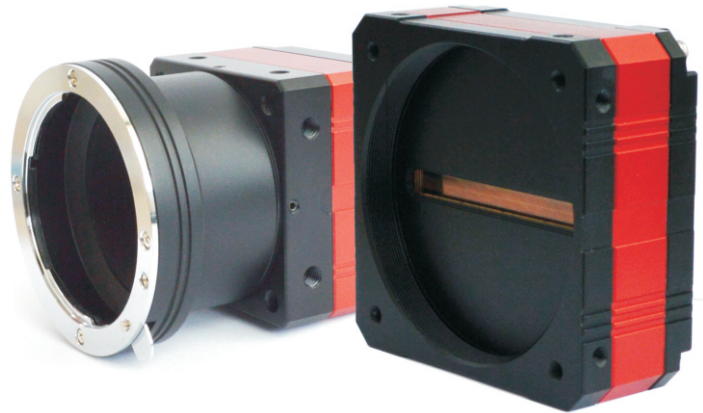

### Key Features

- 2, 4, 8, 16K CMOS Line scan camera
- High sensitivity & Speed
- Standard cameralink interface
- PRNU supported
- CamguideCL

### Dimension (Unit : mm)

[2K, 4K]

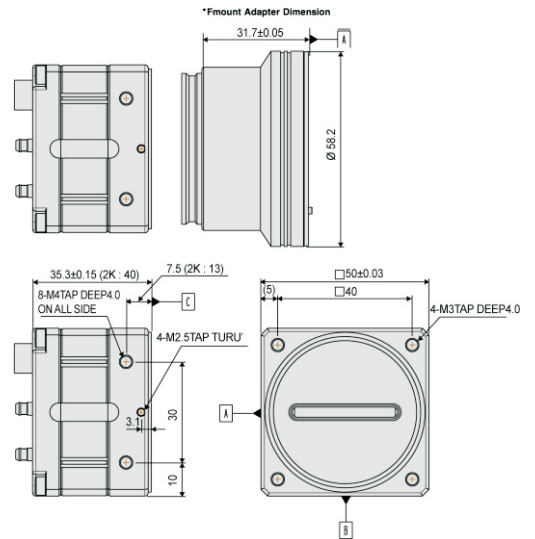

### Pin map

Pin	Name	IN/OUT	Description
1	PWR	IN	10.8V~13.2V Input Range
2	PWR	IN	10.8V~13.2V Input Range
3	-	-	-
4	-	-	-
5	GND	IN	Power GND
6	GND	IN	Power GND

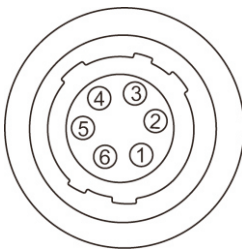

[8K, 16K]

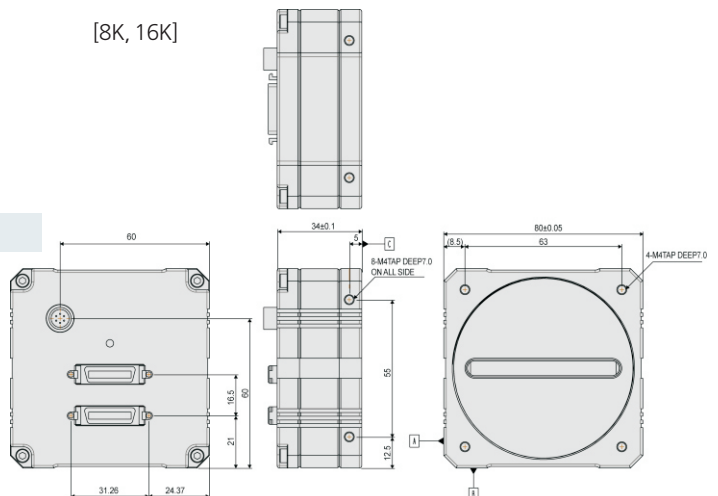

### Download (File name)

ex) SDK download:

CREVIS Site ▶ Search window ▶

CamguideCL : [CamguideCL.zip](#)

Camfile : [Linescan\\_Camfile.zip](#)

Model (Mono)	LV-M422C	LV-M824C
Image sensor	DR-2X2K-7-LCC	DR-2X4K-7
Pixel number	2,048 x 2	4,096 x 2
Sensor size	Linear CMOS	
Pixel size ( $\mu\text{m}$ )	7 x 7	7 x 7
Max. Line rates	141KHz	
Video output type	CameraLink™	
Pixel clock	80MHz	
Gain	0~19dB	
Lens mount	C/F Mount	F Mount
Pixel Data Format	mono 8/10/12	
Gamma	LUT	
Digital I/F	CameraLink Base,Medium	CameraLink Medium, Full
Power requirement	12VDC $\pm$ 10%, PoCL	
Connector	SDR x 2/6pin Circular (Power Only)	
Serial I/F	RS-232C	
Temperature	0°C ~ 45°C	
Operating humidity	Humidity 20% to 80% Non-Condensation	
Housing(W x H x L)	50mm x 50mm x 40mm	50mm x 50mm x 35.3mm
Power consumption	< 2.8W	< 5.3W
Weight	< 188g	< 200g
Alignment accuracy	d $\theta$ :<math>\pm0.2°	
Conformity	CE, RoHS	
Warranty	3 years	

Model (Mono)	LV-M818C	LV-M8116C
Image sensor	DR-1X8K-7	DR-16K-3.5
Pixel number	8,192 x 1	16,384 x 1
Sensor size		
Pixel size (μm)	7 x 7	3.5 x 3.5
Max. Line rates	75KHz	37.5KHz
Video output type	CameraLink™	
Pixel clock	85MHz	
Gain	0~19dB	
Lens mount	M72 Mount	
Pixel Data Format		
Gamma	LUT	
Digital I/F	CameraLink Medium, Full	
Power requirement	12VDC ± 10%	
Connector	MDR x 2/6pin Circular (Power Only)	
Serial I/F	RS-232C	
Temperature		
Operating humidity	Humidity 20% to 80% Non-Condensation	
Housing(W x H x L)	80mm x 80mm x 34mm	
Power consumption	< 6W	< 5.8W
Weight	< 271g	
Alignment accuracy	dθ:<±0.2°	
Conformity	CE, RoHS	
Warranty	3 years	

## Vision Sensor Cameras



### Key Features

- 2K, 8K resolution.
- CAN Interface
- Internal processing
  - Calculate the eight edge point, Focus status
  - Sub-pixel Algorithm(64K)

### Dimension (Unit : mm)

### Pin map

MALE : Phoenix Contact, 1542754

Pin No.	Signal
1	NC
2	PWR
3	NC
4	OV
5	NC
Case(Shield)	FG

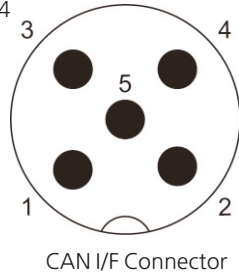

FEMALE : Phoenix Contact, 1542761

Pin No.	Signal
1	CAN-GND
2	GND or NC
3	GND or NC
4	CAN+
5	CAN-
Case(Shield)	FG

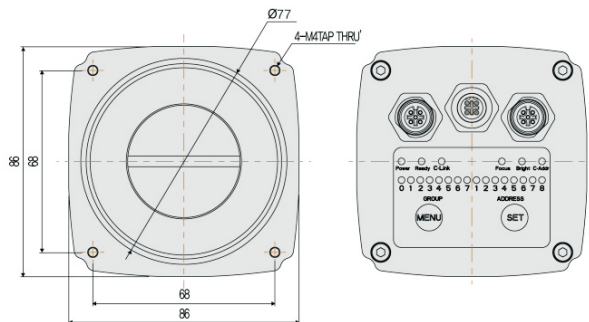
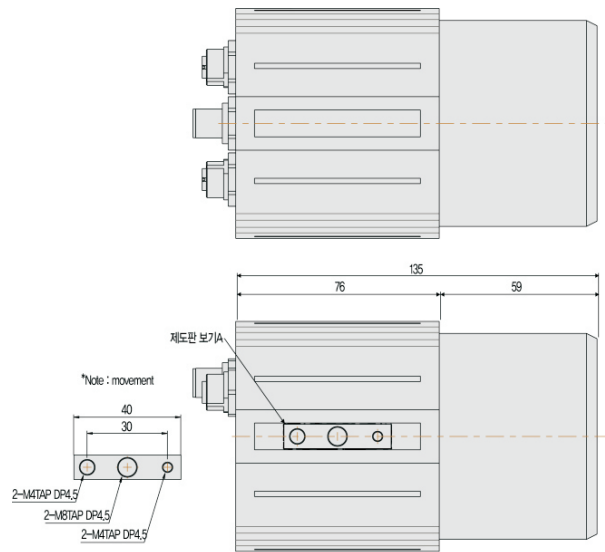
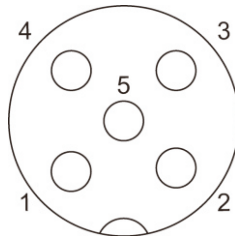

Model (Mono)	SV-B080	Remark	SV-M020	Remark
Lens type	M42 x 1		C-mount	
Measuring range	Depends on lens and distance to lens		Depends on lens and distance to lens	
Resolution	Measuring range / 65,280	64K	Measuring range / 16,384	16K
Sensor type	Linear CCD		Linear CMOS	
Pixel count	8160		2048	
Pixel frequency	7.16MHz		25MHz	
Pixel size(μm)	5 x 5		4 x 4	
Scanning rate	Max. 3.375KHz	Min. 20Hz	Max. 5KHz	
Active CCD length	40.8mm	8160pixel x 5 μm	8.2mm	2048pixel x 4 μm
Spectral maximum	670nm		670nm	
Video out format	8bit	From 10bit A/D	8bit	From 10bit A/D
Scanning mode	Flank Height/Threshold Edge/ Level Edge	Sub-pixel Enable/Disable	Flank Height/Threshold Edge/ Level Edge	Sub-pixel Enable/Disable
Gain range	2~36dB	1024Stage	0~24dB	1024Stage
Camera I/F	CAN Bus	IN/OUT	CAN Bus	IN/OUT
Connector	Standard CAN Connector	5Pin	Standard CAN Connector	5Pin
Data Output frequency	5ms		5ms	
Supply voltage	DC 24V± 20%		DC 24V± 20%	
Power consumption	< 3.5W		< 3W	
Protection class	Ip65	ING	Ip65	ING
Temperature	0℃ ~ 60℃ (Operating) / -20℃ ~ 80℃ (Storage)		0℃ ~ 40℃ (Operating) / -20℃ ~ 60℃ (Storage)	
Dimension	85mm x 85mm x 153.6mm		86mm x 86mm x 137mm	
Weight	< 1250g	Lens weight:194g	< 720g	
Conformity	CE, RoHS		CE, RoHS	

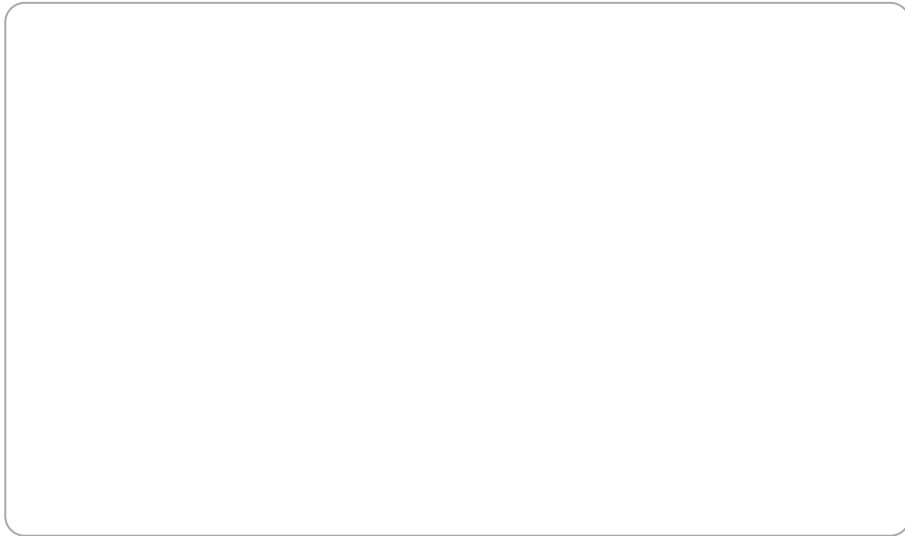

**(주) 크래비스**

[www.crevis.co.kr](http://www.crevis.co.kr)

경기도 용인시 기흥구 기곡로 29-4 (17099)

대표번호 : 031-899-4599

팩스번호 : 031-899-4509

E-mail : [crevis@crevis.co.kr](mailto:crevis@crevis.co.kr)

영업 : 031-899-4503, 4507

29-4, Gigokro, Giheunggu, Yonginsi, Korea (17099)

TEL : +82-31-899-4599

FAX : +82-31-899-4509

E-mail : [crevis@crevis.co.kr](mailto:crevis@crevis.co.kr)

Sales : +82-31-899-4503, 4507